



Product Specification

Part Name: 3.40 inch TFT Display Module

Customer Part ID:

Topovision Part ID: TVT0340A-CP (Round)

Ver: C

Customer:
Approved by

From: Topovision Technology Co., Ltd.
Approved by

Notes:

1. Please contact Topovision Technology Co., Ltd. before assigning your product based on this module specification
2. The information contained herein is presented merely to indicate the characteristics and performance of our products. No responsibility is assumed by Topovision Technology Co., Ltd. for any intellectual property claims or other problems that may result from application based on the module described herein.

Contents

Table of Contents	2
Revision History	3
1 General Specifications	4
2 Input/Output Terminals	5
2.1 LCD interface.....	5
2.2 CTP interfcae.....	6
3 Absolute Maximum Ratings	7
4 Electrical Characteristics.....	7
4.1 LCD characteristics	7
4.2 BL characteristics.....	8
5 Timing Chart.....	9
6 Optical Characteristics	16
7 Environmental / Reliability Test	19
8 Mechanical Drawing.....	20
9 Packing Drawing	21
10 Precautions for Use of LCD Modules	24

1 General Specifications

Feature		Spec
Display Spec.	Size	3.4 inch
	Resolution	800(RGB)×800
	Technology Type	a-Si
	Pixel Configuration	R.G.B. Vertical Stripe
	Pixel pitch(mm)	0.1095×0.1095
	Display Mode	SFT
	Surface Treatment	HC
	Viewing Direction	All direction
Mechanical Characteristics	LCM (W x H x D) (mm)	96.6(W) x 99.0(H) x 2.45(D)
	LCD Active Area(mm)	87.6(W) ×87.6 (H)
	With /Without TSP	With CTP
	Matching Connection Type	ZIF
	LED Numbers	8 white LEDs
	CTP Surface hardness	≥6H
	Weight (g)	62.8 g
Electrical Characteristics	Interface	MIPI 3-Lane
	Color Depth	16.7M
	Driver IC	ILI9881C
	CTP Driver IC	HX8526-E30
	CTP Interface	IIC

Note 1: Viewing direction for best image quality is different from TFT definition. There is a 180 degree shift.

Note 2: Requirements on Environmental Protection: Q/S0002

Note 3: LCM weight tolerance: ± 5%

2 Input/Output Terminals

2.1 LCD Interface

Pin No.	Symbol	I/O	Function	Remark
1	GND	P	Ground	
2	LEDA	P	LED Anode	
3	LEDA	P	LED Anode	
4	LEDK	P	LED Cathode	
5	LEDK	P	LED Cathode	
6	GND	P	Ground	
7	VDD(-5V)	P	-5V INPUT	
8	VDD(-5V)	P	-5V INPUT	
9	GND	P	Ground	
10	VDD(+5V)	P	+5V INPUT	
11	VDD(+5V)	P	+5V INPUT	
12	GND	P	Ground	
13	IOVCC	P	Power supply 1.8V	
14	IOVCC	P	Power supply 1.8V	
15	GND	P	Ground	
16	RESET	I	Global Reset Pin	
17	GND	P	Ground	
18	TE	I	tearing effect output	
19	GND	P	Ground	
20	NC	/	No connect	
21	NC	/	No connect	
22	NC	/	No connect	
23	GND	P	Ground	
24	LAN2_P	I/O	MIPI lane 2+	
25	NC	/	No connect	
26	LAN2_N	I/O	MIPI lane 2-	
27	GND	P	Ground	
28	CLK_P	I/O	MIPI clock +	

29	NC	/	No connect	
30	CLK_N	I/O	IMIPi clock -	
31	GND	P	Ground	
32	LAN1_P	I/O	MIPI lane 1+	
33	NC	/	No connect	
34	LAN1_N	I/O	MIPI lane 1-	
35	GND	P	Ground	
36	LAN0_P	I/O	MIPI lane 0+	
37	NC	/	No connect	
38	LAN0_N	I/O	MIPI lane 0-	
39	GND	P	Ground	

2.2 CTP Interface

Pin No.	Symbol	I/O	Function	Remark
1	VCCA(2.8V)	P	Voltage power	
2	VCCD(1.8V)	P	Power supply 1.8V	
3	SCL	I	I2C SCL signal	
4	SDA	I/O	I2C data input and output	
5	GND	P	Ground	
6	GND	P	Ground	
7	TSIX	I/O	External interrupt to the host	
8	NC	--	No connect	
9	NC	--	No connect	
10	XRES	I	Reset Pin	

3 Absolute Maximum Ratings

GND=0V

Item	Symbol	MIN	MAX	Unit	Remark
Power Supply Voltage	IOVCC	-0.3	3.3	V	Note1
Power Supply Voltage	VDD(+5V)	-0.3	6.5	V	
Power Supply Voltage	VDD(-5V)	-6.5	+0.3	V	
Operating Temperature	Top	-20	70	°C	
Storage Temperature	Tst	-30	80	°C	
Relative Humidity Note2	RH	--	≤95	%	Ta≤40°C
		--	≤85	%	40°C<Ta≤50°C
		--	≤55	%	50°C<Ta≤60°C
		--	≤36	%	60°C<Ta≤70°C
		--	≤24	%	70°C<Ta≤80°C
Absolute Humidity	AH	--	≤70	g/m ³	Ta>70°C

Table 3 Absolute Maximum Ratings

Note1: Input voltage include R0~R5, G0~G5, B0~B5, Dotclk, Hsync, Vsync, Enable, R/L, U/D.

4 Electrical Characteristics

4.1 LCD characteristics

GND=0V, Ta=25°C

Item	Symbol	MIN	TYP	MAX	Unit	Remark
Logic operating voltage	IOVCC	1.7	1.8	1.9	V	
Positive source output voltage	VDD(+5V)	4.9	5	5.1	V	
Negative source output voltage	VDD(-5V)	-5.1	-5	-4.9	V	
Input Signal Voltage	High Level	V _{IH}	0.7*IOVCC	-	IOVCC	V
	Low Level	V _{IL}	0	-	0.3*IOVCC	
Output Voltage	High Level	V _{OH}	0.8 IOVCC	-	IOVCC	
	Low Level	V _{OL}	0	-	0.2 IOVCC	

Table 4.1 LCD module electrical characteristics

4.2 Backlight Unit

Ta=25°C

Item	Symbol	Min	Typ	Max	Unit	Remark
Forward Current	I_F	-	20	-	mA	For each LED
Forward Voltage	V_F	2.9	3.2	3.4	V	For each LED
Operating Life Time	-	-	20,000	-	Hrs	For each LED

Note1: Figure below shows the connection of backlight LED.

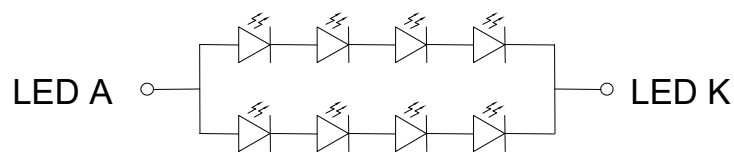

LED CIRCUIT

($I_f=40\text{mA}$ / $V_f=12.8\text{V}$ TYP)

Note 2: 1LED: $V_F = 3.2\text{V}$ $I_F = 20\text{mA}$

Note 3: I_F is defined for one LED.

Optical performance should be evaluated at $T_a=25^\circ\text{C}$ only.

If LED is driven by high current, high ambient temperature & humidity condition. The life time of LED will be reduced. Operating life means brightness goes down to 50% initial brightness. Typical operating life time is estimated data

5 Timing Chart

5.1 LCM Timing

5.1.1 Reset timing characteristics

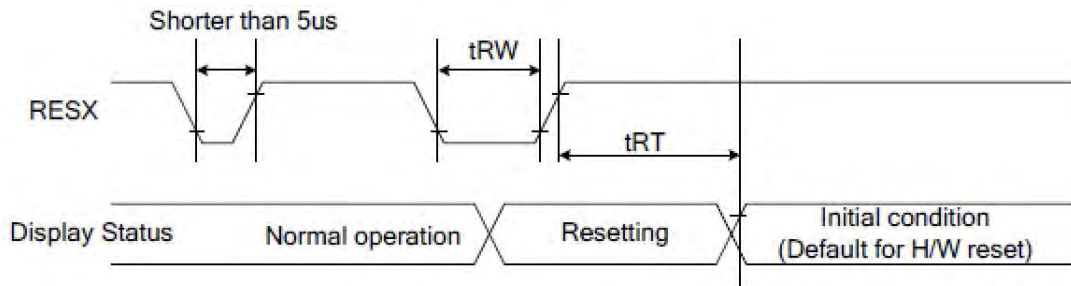

Figure 124: Reset Timing

Table 47: Reset Timing

Signal	Symbol	Parameter	Min	Max	Unit
RESX	tRW	Reset pulse duration	10		uS
	tRT	Reset cancel		5 (note 1,5) 120 (note 1,6,7)	mS

Notes:

- The reset cancel also includes required time for loading ID bytes, VCOM setting and other settings from EEPROM to registers. This loading is done every time when there is H/W reset cancel time (tRT) within 5 ms after a rising edge of RESX.
- Spike due to an electrostatic discharge on RESX line does not cause irregular system reset according to the Table 48.

Table 48: Reset Descript

RESX Pulse	Action
Shorter than 5us	Reset Rejected
Longer than 10us	Reset
Between 5us and 10us	Reset starts

- During the Resetting period, the display will be blanked (The display enters the blanking sequence, which maximum time is 120 ms, when Reset Starts in the Sleep Out mode. The display remains the blank state in the Sleep In mode.) and then return to Default condition for Hardware Reset.
- Spike Rejection can also be applied during a valid reset pulse, as shown below:

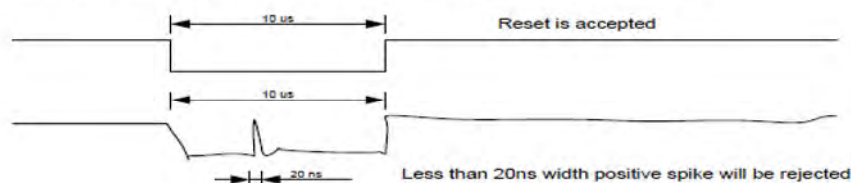

Figure 125: Positive Noise Pulse during Reset Low

- When Reset applied during Sleep In Mode.
- When Reset applied during Sleep Out Mode.
- It is necessary to wait 5msec after releasing RESX before sending commands. Also Sleep Out command cannot be sent for 120msec.

5.1.2 High Speed Mode

18.4.2. High Speed Mode – Clock Channel Timing

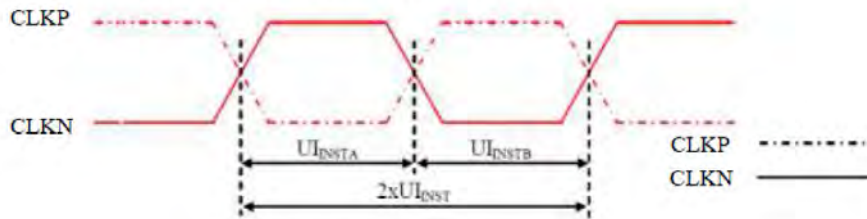

Figure 116: DSI Clock Channel Timing

Table 38: DSI Clock Channel Timing

Signal	Symbol	Parameter	Min	Max	Unit
CLKP/N	$2xUI_{INST}$	Double UI instantaneous	Note 2	25	ns
CLKP/N	UI_{INSTA}, UI_{INSTB} (Note 1)	UI instantaneous Half	Note 2	12.5	ns

Notes:

1. $UI = UI_{INSTA} = UI_{INSTB}$
2. Define the minimum value, see Table 39.

Table 39: Limited Clock Channel Speed

Data type	Two Lanes speed	Three Lanes speed	Four Lanes speed
Data Type = 00 1110 (0Eh), RGB 565, 16 UI per Pixel	566 Mbps	466 Mbps	366 Mbps
Data Type = 01 1110 (1Eh), RGB 666, 18 UI per Pixel	637 Mbps	525 Mbps	412 Mbps
Data Type = 10 1110 (2Eh), RGB 666 Loosely, 24 UI per Pixel	850 Mbps	700 Mbps	550 Mbps
Data Type = 11 1110 (3Eh), RGB 888, 24 UI per Pixel	850 Mbps	700 Mbps	550 Mbps

18.4.3. High Speed Mode – Data Clock Channel Timing

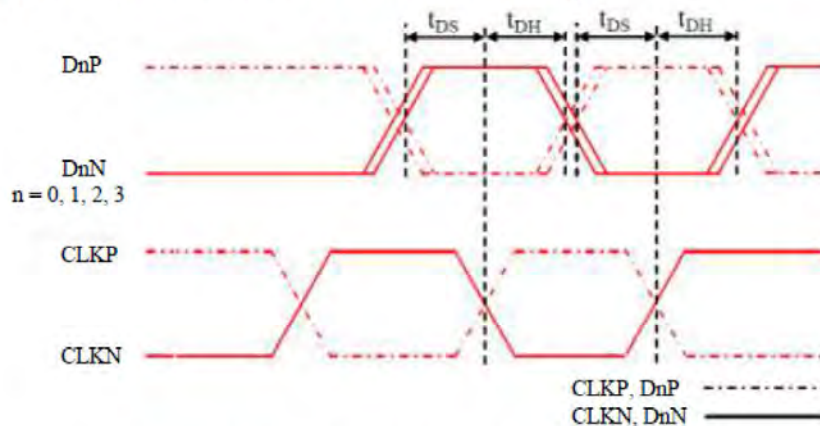

Figure 117: DSI Data to Clock Channel Timings

Table 40: DSI Data to Clock Channel Timings

Signal	Symbol	Parameter	Min	Max
DnP/N, n=0 and 1	t_{DS}	Data to Clock Setup time	$0.15xUI$	-
	t_{DH}	Clock to Data Hold Time	$0.15xUI$	-

18.4.4. High Speed Mode – Rising and Falling Timings

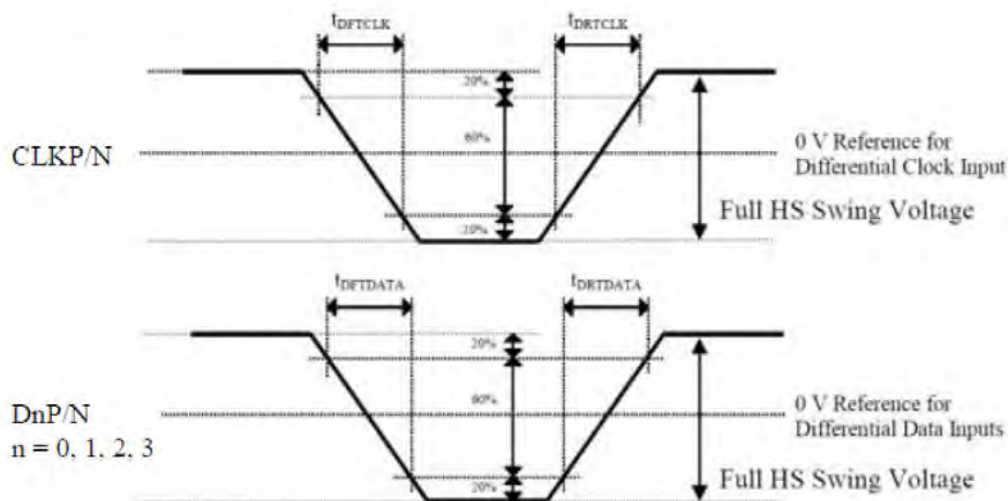

Figure 118: Rising and Falling Timings on Clock and Data Channels

Table 41: Rise and Fall Timings on Clock and Data Channels

Parameter	Symbol	Condition	Specification		
			Min	Typ	Max
Differential Rise Time for Clock	$t_{DRTCCLK}$	CLKP/N	150 ps	-	0.3UI (Note)
Differential Rise Time for Data	$t_{DRTDATA}$	DnP/N n=0 and 1	150 ps	-	0.3UI (Note)
Differential Fall Time for Clock	t_{DFTCLK}	CLKP/N	150 ps	-	0.3UI (Note)
Differential Fall Time for Data	$t_{DFTDATA}$	DnP/N n=0 and 1	150 ps	-	0.3UI (Note)

Note: The display module has to meet timing requirements, which are defined for the transmitter (MCU) on MIPI D-Phy standard.

5.1.3 Low Speed Mode

18.4.5. Low Speed Mode – Bus Turn Around

Lower Power Mode and its State Periods on the Bus Turnaround (BTA) from the MCU to the Display Module (ILI9881C) are illustrated for reference purposes below.

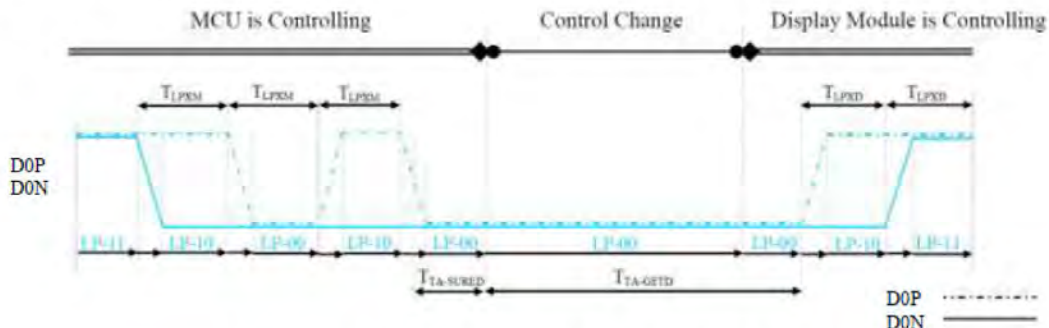

Figure 119: BTA from the MCU to the Display Module

Lower Power Mode and its State Periods on the Bus Turnaround (BTA) from the Display Module (ILI9881C) to the MCU are illustrated for reference purposes below.

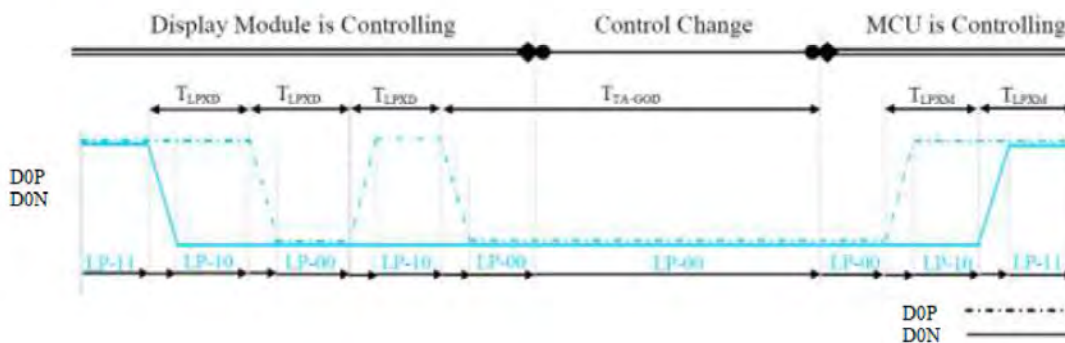

Figure 120: BTA from the Display Module to the MCU

Table 42: Low Power State Period Timings – A

Signal	Symbol	Description	Min	Max	Unit
D0P/N	T_{LPXM}	Length of LP-00, LP-01, LP-10 or LP-11 periods MCU → Display Module (ILI9881C)	50	75	ns
D0P/N	T_{LPKD}	Length of LP-00, LP-01, LP-10 or LP-11 periods Display Module (ILI9881C) → MCU	50	75	ns
D0P/N	$T_{TA-SURED}$	Time-out before the Display Module (ILI9881C) starts driving	T_{LPKD}	$2 \times T_{LPKD}$	ns

Table 43: Low Power State Period Timings – B

Signal	Symbol	Description	Time	Unit
D0P/N	$T_{TA-GETD}$	Time to drive LP-00 by Display Module (ILI9881C)	$5 \times T_{LPKD}$	ns
D0P/N	T_{TA-G0D}	Time to drive LP-00 after turnaround request - MCU	$4 \times T_{LPKD}$	ns

18.4.6. Data Lanes from Low Power Mode to High Speed Mode

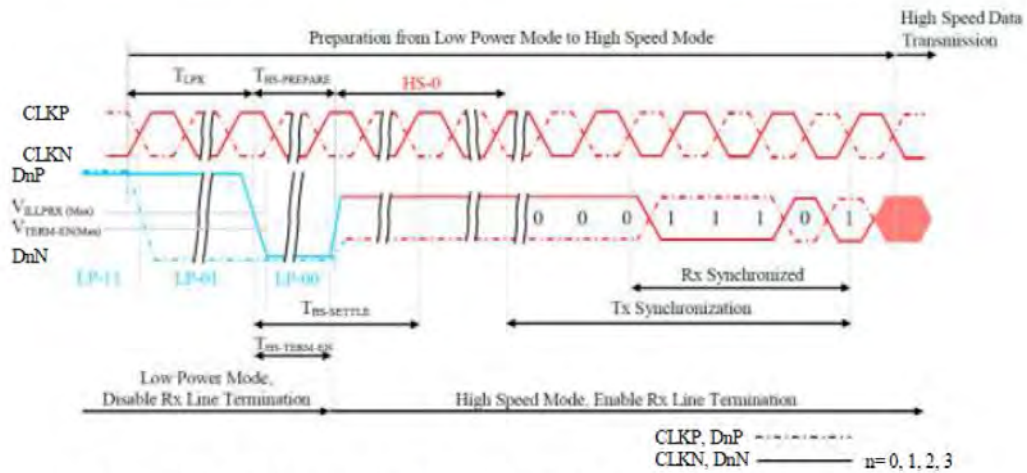

Figure 121: Data Lanes - Low Power Mode to High Speed Mode Timings

Table 44: Data Lanes - Low Power Mode to High Speed Mode Timings

Signal	Symbol	Description	Min	Max	Unit
DnP/N, n = 0 and 1	T_{LPX}	Length of any Low Power State Period	50	-	ns
DnP/N, n = 0 and 1	$T_{HS-PREPARE}$	Time to drive LP-00 to prepare for HS Transmission	$40+4xUI$	$85+6xUI$	ns
DnP/N, n = 0 and 1	$T_{HS-TERM-EN}$	Time to enable Data Lane Receiver line termination measured from when Dn crosses VILMAX	-	$35+4xUI$	ns

18.4.7. Data Lanes from High Speed Mode to Low Power Mode

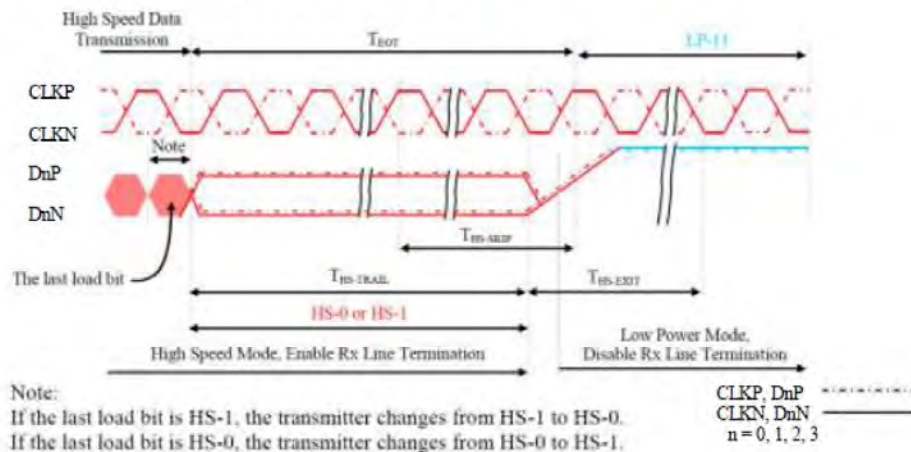
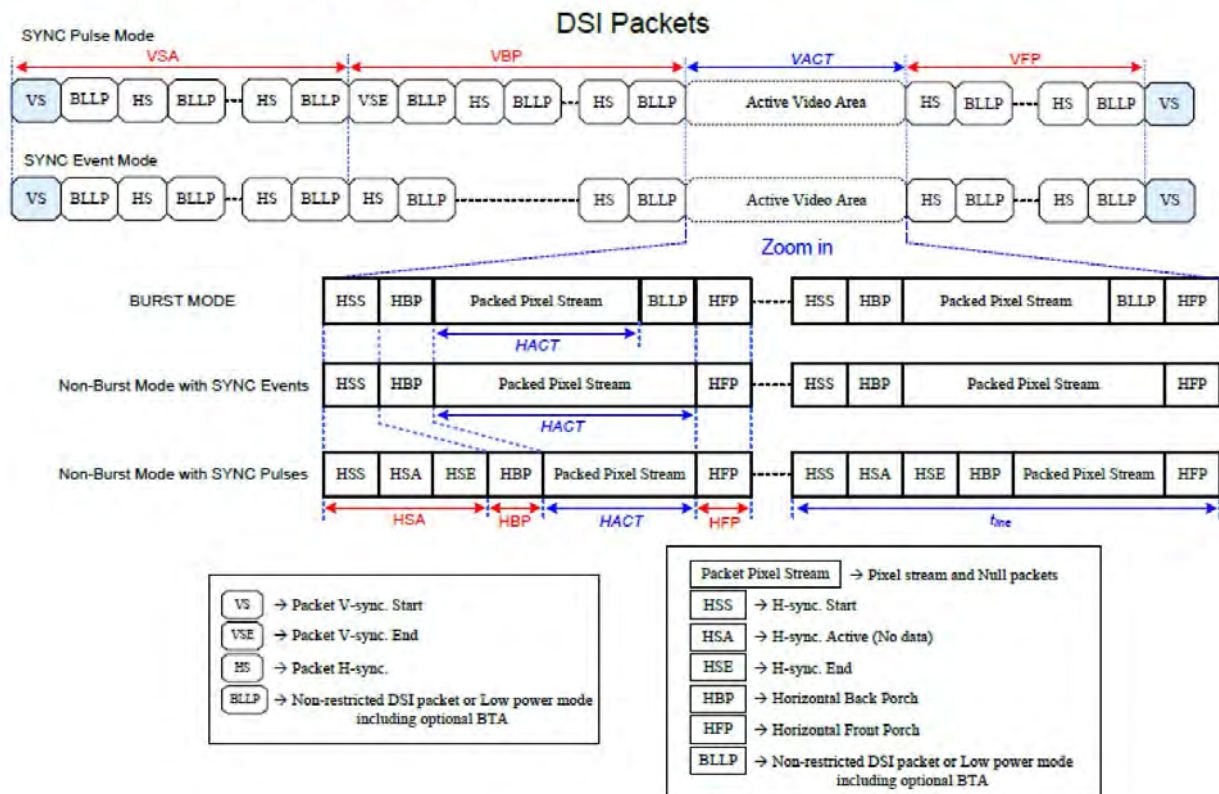

Figure 122: Data Lanes - High Speed Mode to Low Power Mode Timings

Table 45: Data Lanes - High Speed Mode to Low Power Mode Timings

Signal	Symbol	Description	Min	Max	Unit
DnP/N, n = 0 and 1	$T_{HS-SKIP}$	Time-Out at Display Module (ILI9881C) to ignore transition period of EoT	40	$55+4xUI$	ns
DnP/N, n = 0 and 1	$T_{HS-EXIT}$	Time to driver LP-11 after HS burst	100	-	ns

18.4.9. Timing for DSI video mode



Parameters	Symbols	Min.	Typ.	Max.	Units
Vertical sync. active	VSA	2 (Note 6)	-	-	Line
Vertical Back Porch	VBP	14 (Note 6)	-	-	Line
Vertical Front Porch	VFP	8 (Note 6)	-	-	Line
Active lines per frame	VACT	-	1280	-	Line
Horizontal sync. active	HSA	2	-	-	Pixel
Horizontal Porch period	HSA + HBP + HFP	1.6	-	-	us
Active pixels per line	HACT	-	720	-	Pixel
Bit rate	BR _{bps}	385		Note 5	Mbps/lane

1 UI=1/Bit rate

$$HSA(\text{pixel}) = (tHSA \times \text{lane number}) / (UI \times \text{pixel format})$$

$$HBP(\text{pixel}) = (tHBP \times \text{lane number}) / (UI \times \text{pixel format})$$

$$HFP(\text{pixel}) = (tHFP \times \text{lane number}) / (UI \times \text{pixel format})$$

$$\text{Frame Rate} = \frac{BR_{\text{bps}} \times \text{Lane}_{\text{num}}}{(VACT + VSA + VBP + VFP) \times (HACT + HSA + HBP + HFP) \times \text{Pixel Format}}$$

Example : BR_{bps} = 457Mbps/lane, 1UI=2.1883ns, Frame rate=60Hz, VACT=1280, VSA=2, VBP=30, VFP=20, HACT=720, HSA=33, HBP=100, HFP=100, Lane_{num}=4(lane), Pixel Format=24(bit).

5.1.4 POWER ON/OFF SEQUENCE

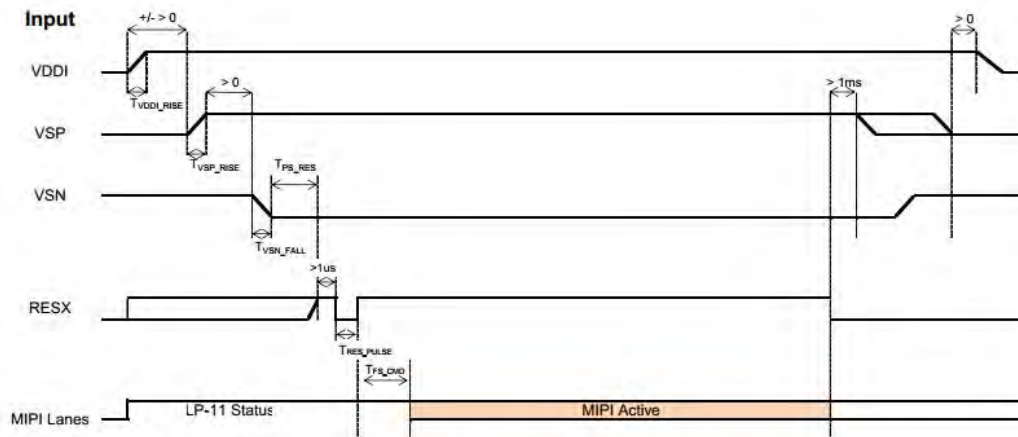

Symbol	Characteristics	Min.	Typ.	Max.	Units
T_{VDDI_RISE}	VDDI Rise time	10	-	-	us
T_{VSP_RISE}	VSP Rise time	130	-	-	us
T_{VSN_FALL}	VSN Fall time	200	-	-	us
T_{PS_RES}	VDDI/VSP on to Reset high	5	-	-	ms
T_{RES_PULSE}	Reset low pulse time	10	-	-	us
T_{FS_CMD}	Reset to first command	10	-	-	ms

6 Optical Characteristics

6.1 Driving the backlight condition

Item	Symbol	Condition	Min	Typ	Max	Unit	Remark	
View Angles	θT	$CR \geq 10$	70	80	-	Degree	Note2	
	θB		70	80	-			
	θL		70	80	-			
	θR		70	80	-			
Contrast Ratio	CR	$\theta=0^\circ$	600	800	-		Note 3	
Chromaticity	White	Backlight is on	x	0.263	0.313	0.365		Note 1,5
			y	0.279	0.329	0.379		
Uniformity	U		75	80	-	%	Note 6	
Response Time	Ton+Toff	-	-	25	35		Note 1,4	
NTSC	-	-	65	70	-	%	Note 5	
Luminance	L	-	280	350	-	cd/m ²	Note 7	

Test Conditions:

- $I_F = 20$ mA(one LED), and the ambient temperature is 25°C.
- The test systems refer to Note 1 and Note 2.

Note 1: Definition of optical measurement system.

The optical characteristics should be measured in dark room. After 5 Minutes operation, the optical properties are measured at the center point of the LCD screen. All input terminals LCD panel must be ground when measuring the center area of the panel.

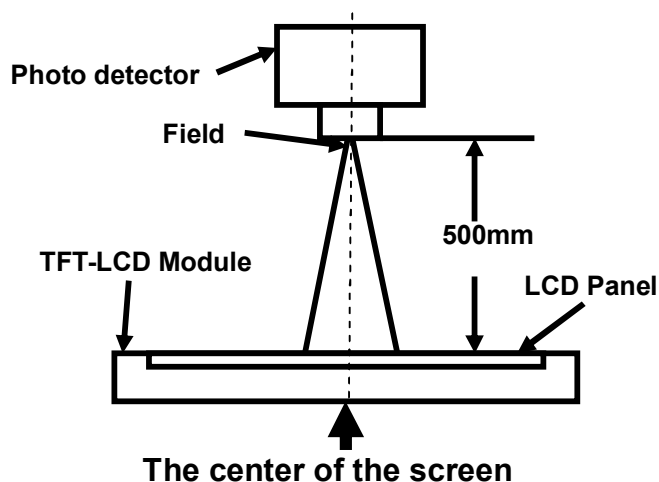

Note 2: Definition of viewing angle range and measurement system.

viewing angle is measured at the center point of the LCD

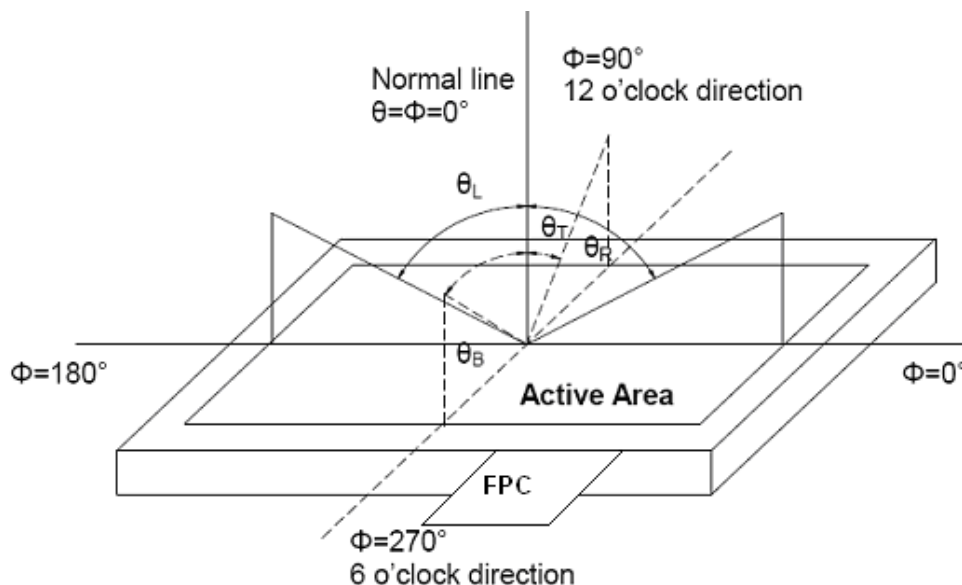

Note 3: Definition of contrast ratio

$$\text{Contrast ratio (CR)} = \frac{\text{Luminance measured when LCD is on the "White" state}}{\text{Luminance measured when LCD is on the "Black" state}}$$

“White state “: The state is that the LCD should drive by V_{white} .

“Black state”: The state is that the LCD should drive by V_{black} .

V_{white} : To be determined V_{black} : To be determined.

Note 4: Definition of Response time

The response time is defined as the LCD optical switching time interval between “White” state and “Black” state. Rise time (T_{ON}) is the time between photo detector output intensity changed from 90% to 10%. And fall time (T_{OFF}) is the time between photo detector output intensity changed from 10% to 90%.

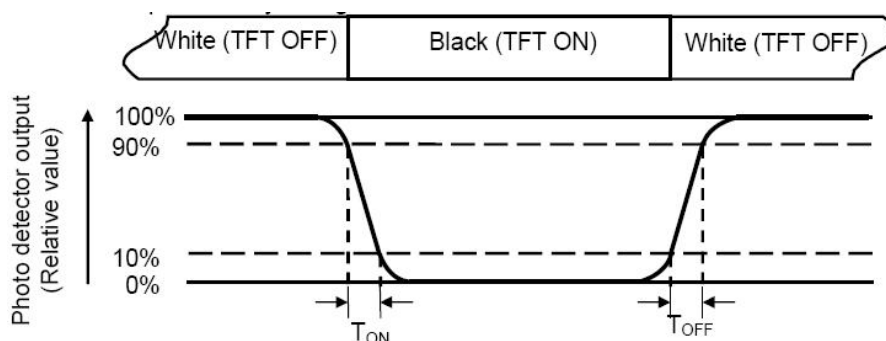

Note 5: Definition of color chromaticity (CIE1931)

Color coordinates measured at center point of LCD.

Note 6: Definition of Luminance Uniformity

Active area is divided into 9 measuring areas (Refer Fig. 2). Every measuring point is placed at the center of each measuring area.

Luminance Uniformity (U) = L_{min} / L_{max}

L-----Active area length W----- Active area width

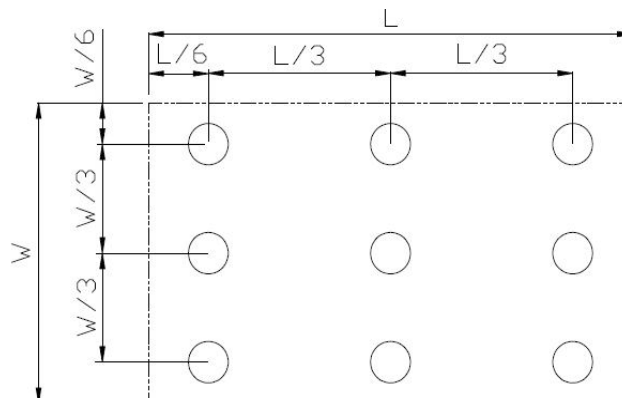

L_{max} : The measured Maximum luminance of all measurement position.

L_{min} : The measured Minimum luminance of all measurement position.

Note 7: Definition of Luminance: Measure the luminance of white state at center point.

7 Environmental / Reliability Test

7.1 LCM+CTP

No	Test Item	Condition	Remarks
1	High Temperature Operation	Ts=+70°C±2°C, 120hrs	IEC60068-2-1:2007 GB2423.2-2008
2	Low Temperature Operation	Ta=-20°C±2°C, 120hrs	IEC60068-2-1:2007 GB2423.1-2008
3	High Temperature Storage	Ta=+80°C±2°C, 120hrs	IEC60068-2-1:2007 GB2423.2-2008
4	Low Temperature Storage	Ta=-30°C±2°C, 120hrs	IEC60068-2-1:2007 GB2423.1-2008
5	Storage at High Temperature and Humidity	Ta=+60°C, 90% RH, 120hrs	IEC60068-2-78 :2001 GB/T2423.3—2006
6	Thermal Shock (non-operation)	(-30°C/30min~80°C/30min)*20 cycles Change Speed: 8°C/min	Start with cold temperature, End with high temperature, IEC60068-2-14:1984,G B2423.22-2002
7	Electro Static Discharge (operation)	C=150pF R=330Ω Air: ±8KV Contact:±4KV 5point/panel, 5times	IEC61000-4-2:2001 GB/T17626.2-2006

Note1: Ts is the temperature of panel's surface.

Note2: Ta is the ambient temperature of sample.

Note3: Before cosmetic and function test, the product must have enough recovery time, at least 2 hours at room temperature.

Note 4: In the standard condition, there shall be no practical problem that may affect the display function. After the reliability test, the product only guarantees operation, but don't guarantee all of the cosmetic specification.

8 Mechanical Drawing

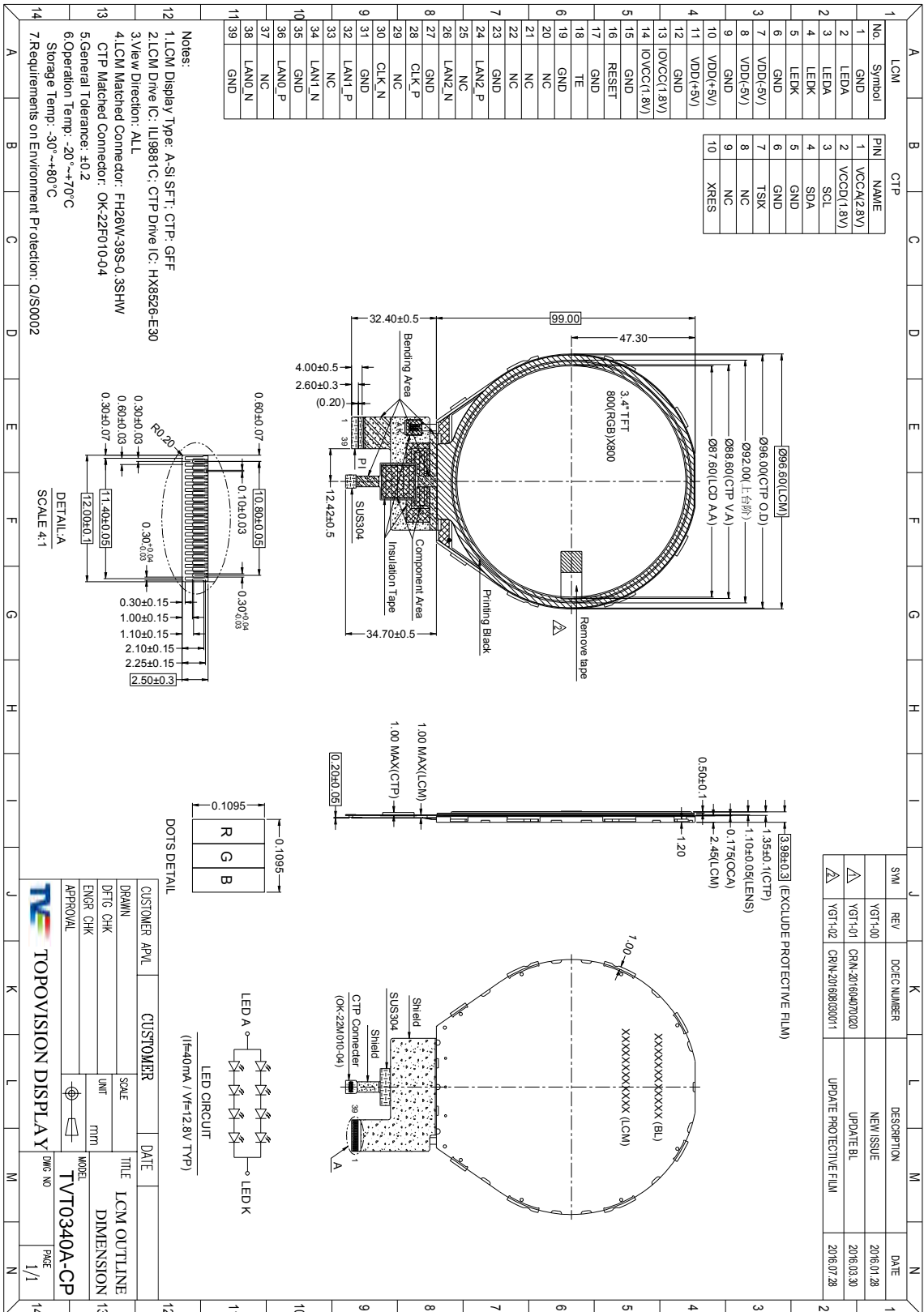

9 Packing Drawing

9.1 Per Carton

No	Item	Model (Materiel)	Dimensions(mm)	Unit Weight(Kg)	Quantity	Remark
1	LCM module		96.6×99.0×3.98mm	0.063	96	
2	Tray		356x256x13.50	0.08	26	
3	EPE (珍珠棉1)		312.67×216×1mm	0.0012	24	
4	EPE (珍珠棉2)		336×246×6mm	0.01	4	
5	EPE (珍珠棉3)		375×275×10mm	0.014	4	
6	EPE (珍珠棉4)		250×280×12mm	0.015	2	
7	Carton (纸箱)		395×290×315mm	0.58	1	
8	Total weight	8.86±5%				

9.2 Packaging Specification and Quantity

(1) LCM quantity per tray (每盘模组数量) :4 pcs
(2) Total LCM quantity per group (每组模组总数量): 48 pcs (12Tray盘+1 Empty tray空盘)
(3) Total LCM quantity per Carton (每箱模组总数量): quantity per group (每组模组总数量) 48 pcs × group quantity per Carton (每箱组数量) 2= 96 pcs

9.3 Packing Form

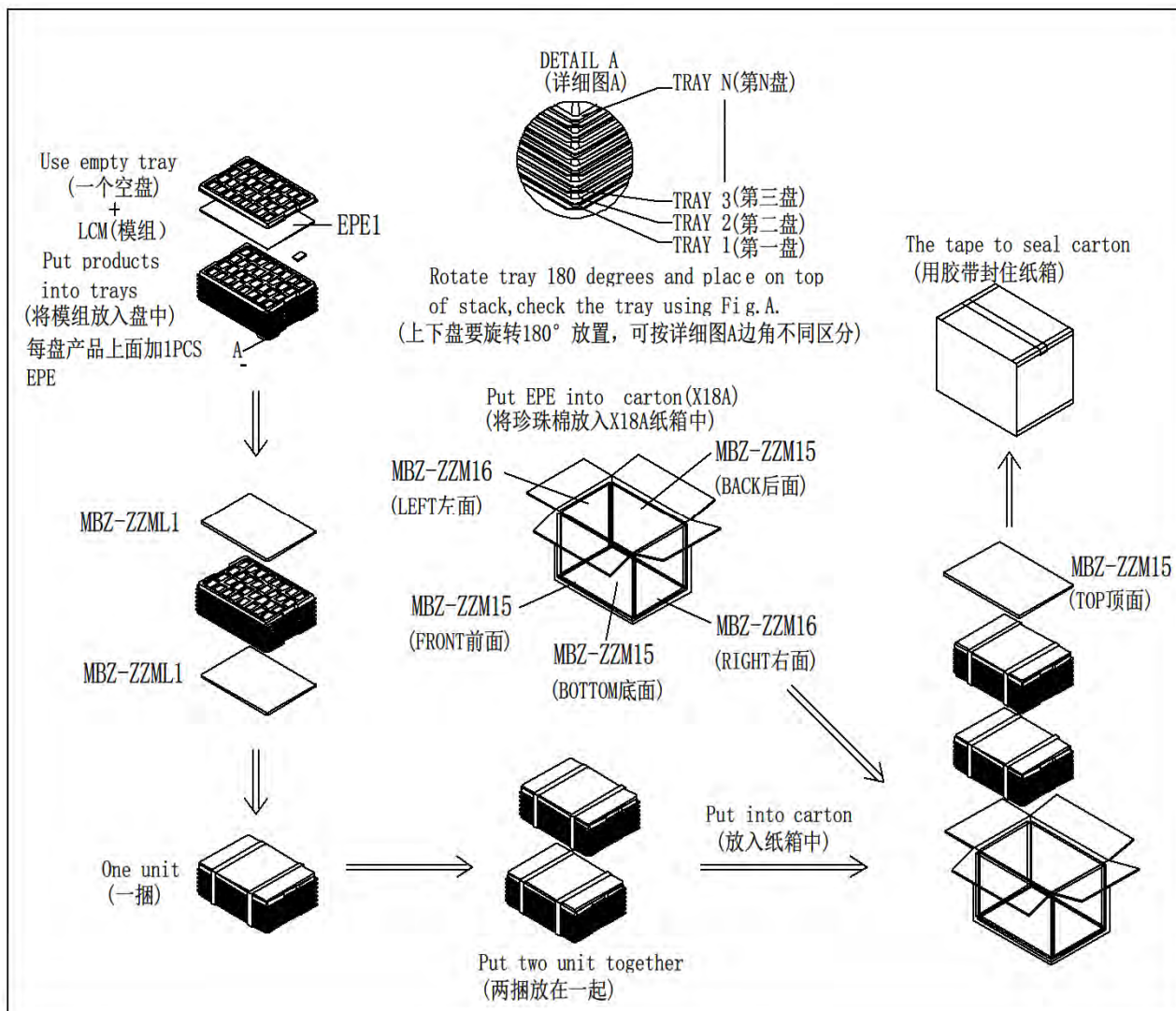

9.4 Shipping Package of Palletizing Sequence

纸箱堆叠数按 2×3/每层×共 5 层

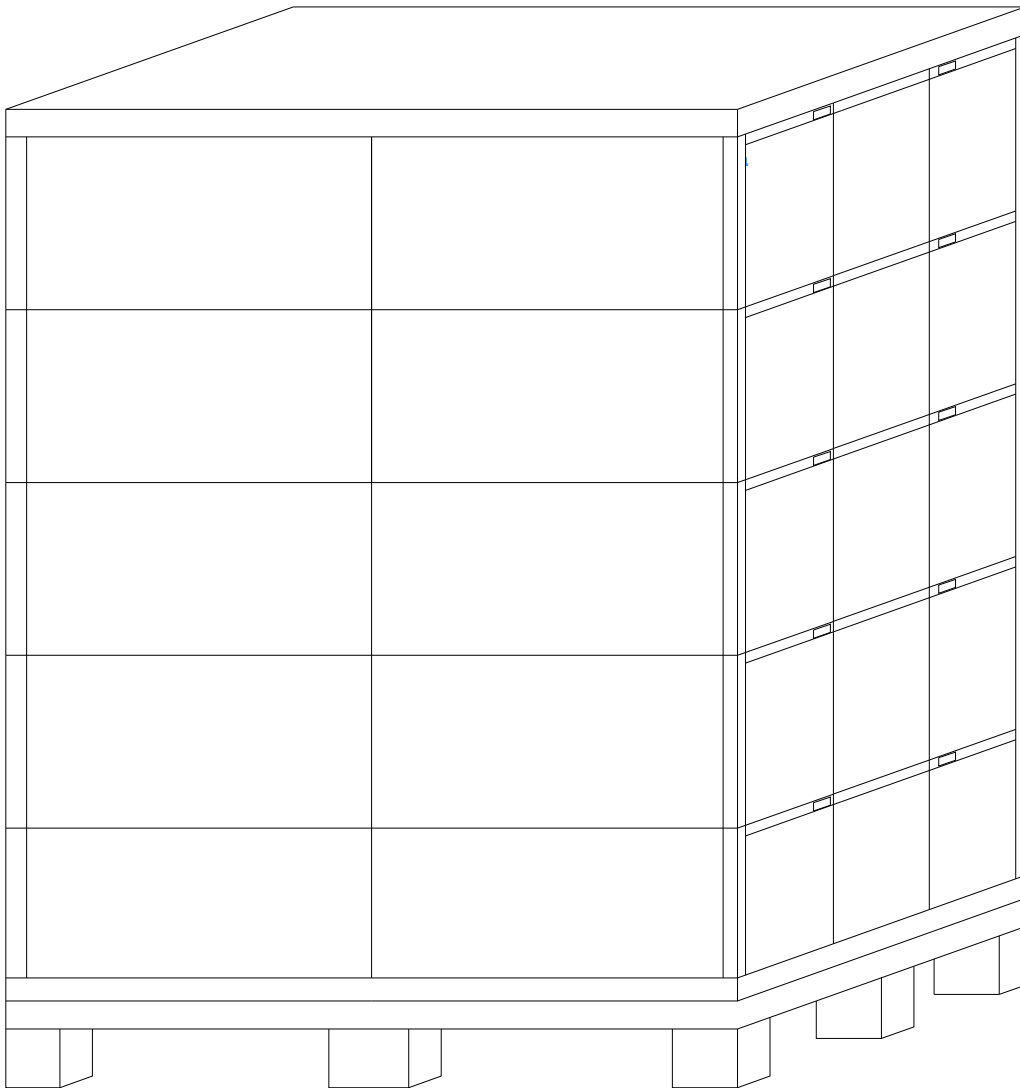

10 Precautions for Use of LCD Modules

10.1 Handling Precautions

10.1.1 The display panel is made of glass. Do not subject it to a mechanical shock by dropping it from a high place, etc.

10.1.2 If the display panel is damaged and the liquid crystal substance inside it leaks out, be sure not to get any in your mouth, if the substance comes into contact with your skin or clothes, promptly wash it off using soap and water.

10.1.3 Do not apply excessive force to the display surface or the adjoining areas since this may cause the color tone to vary.

10.1.4 The polarizer covering the display surface of the LCD module is soft and easily scratched. Handle this polarizer carefully.

10.1.5 If the display surface is contaminated, breathe on the surface and wipe with a soft dry cloth. If still not completely clear, moisten cloth with one of the following solvents:

- Isopropyl alcohol
- Ethyl alcohol

Solvents other than those mentioned above may damage the polarizer. Especially, do not use the following:

- Water
- Ketone
- Aromatic solvents

10.1.6 Do not attempt to disassemble the LCD Module.

10.1.7 If the logic circuit power is off, do not apply the input signals.

10.1.8 To prevent destruction of the elements by static electricity, be careful to maintain an optimum work environment.

10.1.8.1 Be sure to ground the body when handling the LCD Modules.

10.1.8.2 Tools required for assembly, such as soldering irons, must be properly ground.

10.1.8.3 To reduce the amount of static electricity generated, do not conduct assembly and other work under dry conditions.

10.1.8.4 The LCD Module is coated with a film to protect the display surface. Be care when peeling off this protective film since static electricity may be generated.

10.2 Storage precautions

10.2.1 When storing the LCD modules, avoid exposure to direct sunlight or to the light of fluorescent lamps.

10.2.2 The LCD modules should be stored under the storage temperature range. If the LCD modules will be stored for a long time, the recommend condition is:

Temperature : 0°C ~ 40°C Relatively humidity: ≤80%

10.2.3 The LCD modules should be stored in the room without acid, alkali and harmful gas.

10.3 Transportation Precautions

10.3.1 The LCD modules should be no falling and violent shocking during transportation, and also should avoid excessive press, water, damp and sunshine.