



Product Specification

Part Name: 8.80 inch TFT Display Module

Customer Part ID:

Topovision Part ID: TVT0800B-I

Ver: A

Customer:
Approved by

From: Topovision Technology Co., Ltd.
Approved by

Notes:

1. Please contact Topovision Technology Co., Ltd. before assigning your product based on this module specification
2. The information contained herein is presented merely to indicate the characteristics and performance of our products. No responsibility is assumed by Topovision Technology Co., Ltd. for any intellectual property claims or other problems that may result from application based on the module described herein.

Revision History

Rev.	Date	Contents	Written	Approved
A	2017/01/07	Preliminary Specification	Sam	Kevin

Special Notes

Note1.	

Contents

1.0	General description	p.4
2.0	Absolute maximum ratings.....	p.5
3.0	Optical characteristics.....	p.6
4.0	Block diagram	p.10
5.0	Interface pin connection	p.13
6.0	Electrical characteristics	p.16
7.0	Reliability test items	p.21
8.0	Outline dimension	p.22
9.0	Lot mark	p.24
10.0	Package specification	p.25
11.0	General precaution	p.26

1.0 GENERAL DESCRIPTION

1.1 Introduction

TOPOVISION Display model TVT0800B-I is a color active matrix thin film transistor (TFT) liquid crystal display (LCD) that uses amorphous silicon TFT as a switching device. This model is composed of a TFT LCD panel, a driving circuit and a back light system. This TFT LCD has a 8.8 (1:4) inch diagonally measured active display area with (480 horizontal by 1920 vertical pixel) resolution.

1.2 Features

- 8.8 inch (1:4 diagonal) configuration
- 16.7M color
- RoHS/ Halogen Free Compliance

1.3 Applications

- Automotive

1.4 TFT LCD General information

Item		Specification	Unit
Outline Dimension		64.3 x 231.3 (typ)	mm
Display area		54.72(H) x 218.88(V)	mm
Number of Pixel		480 RGB (H) x 1920(V)	pixels
Pixel pitch		0.114(H) x 0.114(V)	mm
Pixel arrangement		RGB Vertical stripe	
Display mode		Normally Black	
NTSC		50 (typ.)	%
Surface treatment		HC	
Weight		(100)g (Typ.)	g
Back-light		White LED	
Power Consumption	Logic	0.65 (Max) @ White pattern · Frame rate 60Hz	W
	BL System	2.8 (Max) @ Black pattern w/o LED driver	W

1.5 Mechanical Information

Item		Min.	Typ.	Max.	Unit
Module Size	Horizontal (H)	64.0	64.3	64.6	mm
	Vertical (V)	231.0	231.3	231.6	mm
	Depth (D)	—	4.8	5.1	mm
Weight		—	(100)	—	g

2.0 ABSOLUTE MAXIMUM RATINGS

2.1 Electrical Absolute Rating

2.1.1 TFT LCD Module

Item	Symbol	Min.	Max.	Unit	Note
Power supply voltage	V_{DD}	-0.5	4.0	V	
	V_{GH}	15	26	V	
	V_{GL}	-11.5	-4	V	
	AV_{DD}	7	12.5	V	
Logic Signal Input Level	V_{DD}	-0.5	4.0	V	

2.1.2 Backlight unit

Item	Symbol	Typ.	Max.	Unit	Note
LED current	I_L	160	-	mA	(1) (2)(3)
LED voltage	V_L	17	20.4	V	(1) (2)(3)
LED reverse voltage	V_R	--	5	V	
LED forward current	I_F		20	mA	

Note:

- (1) Permanent damage may occur to the LCD module if beyond this specification. Functional operation should be restricted to the conditions described under normal operating conditions.
- (2) $T_a = 25 \pm 2^\circ\text{C}$
- (3) Test Condition: LED current 140 mA. The LED lifetime could be decreased if operating I_L is larger than 140mA.

2.1.3 Environment Absolute Rating

Item	Symbol	Min.	Max.	Unit	Note
Operating Temperature	T_{opa}	-20	70	$^\circ\text{C}$	
Storage Temperature	T_{stg}	-30	80	$^\circ\text{C}$	

3.0 OPTICAL CHARACTERISTICS

3.1 Optical specification

Item	Symbol	Condition	Min.	Typ.	Max.	Unit	Note
Contrast	CR	$\Theta=0$ Normal viewing angle	600	800	—		(1)(2)(4)
Response time	Tr+Tf		—	30	40	msec	(1)(3)
White luminance (Center)	Y_L		480	600	—	cd/m ²	(1)(4) ($I_L=160mA$)
Color chromaticity (CIE1931)	Red		R_x		TBD		c-light
			R_y		TBD		
	Green		G_x		TBD		
			G_y		TBD		
	Blue	B_x		TBD			
		B_y		TBD			
White	W_x	0.263	0.313	0.363			
	W_y	0.279	0.329	0.379			
Viewing angle	Hor.	Θ_L	75	85	—	(1)(4)	
		Θ_R	75	85	—		
	Ver.	Θ_U	75	85	—		
		Θ_D	75	85	—		
Brightness uniformity	B_{UNI}	$\Theta=0$ (9point)	70	80	—	(5)	
View Direction	ALL						(6)

3.2 Measuring Condition

- Measuring surrounding : dark room
- LED current I_L : 160mA
- Ambient temperature : $25\pm 2^\circ C$
- 15min. warm-up time.

3.3 Measuring Equipment

- FPM520 of Westar Display technologies, INC., which utilized SR-3 for Chromaticity and BM-5A for other optical characteristics.
- Measuring spot size : 20 ~ 21 mm

Note (1) Definition of Viewing Angle:

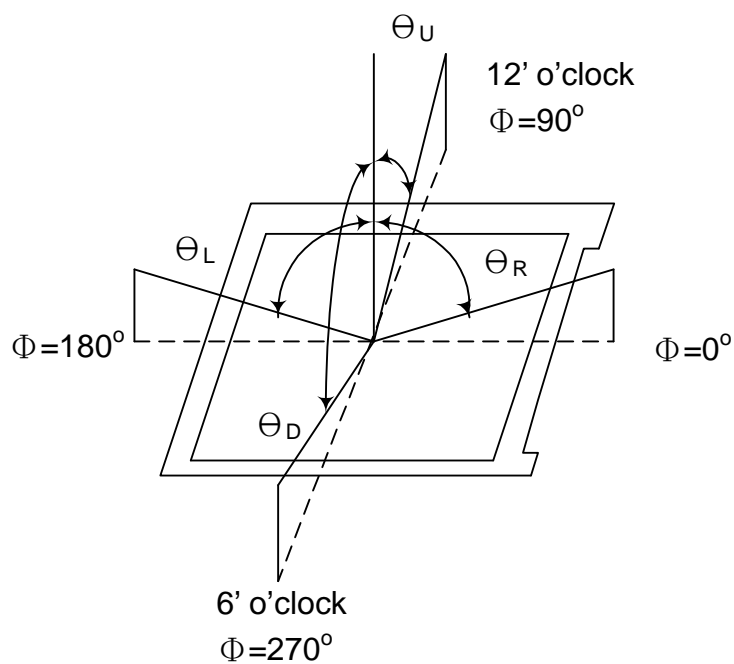

Note (2) Definition of Contrast Ratio (CR) :
measured at the center point of panel

$$CR = \frac{\text{Luminance with all pixels white}}{\text{Luminance with all pixels black}}$$

Note (3) Definition of Response Time : Sum of T_R and T_F

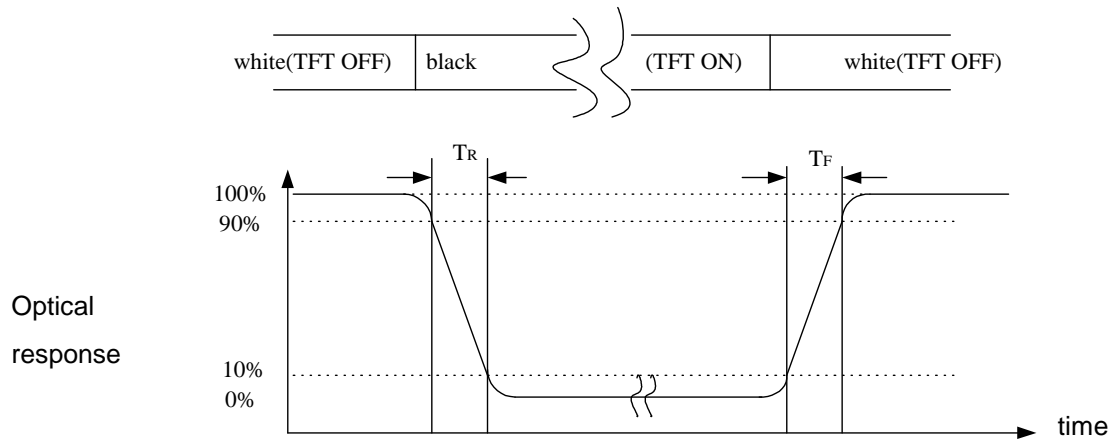

Note (4) Definition of optical measurement setup

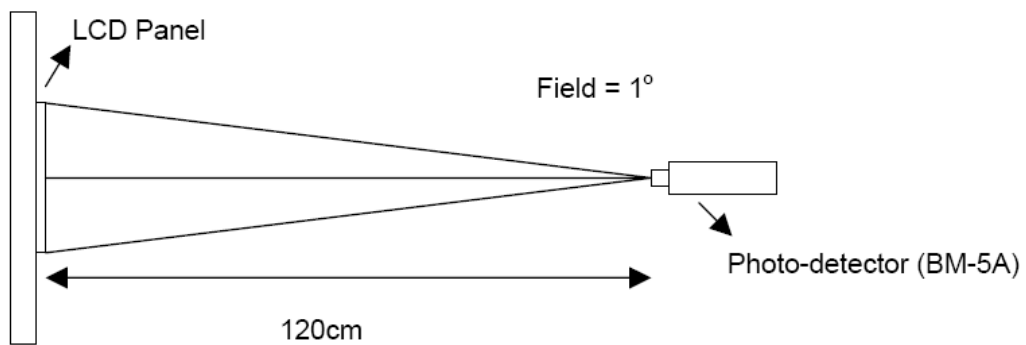

Note (5) Definition of Average Luminance Uniformity of White (Center)
 Definition of brightness uniformity

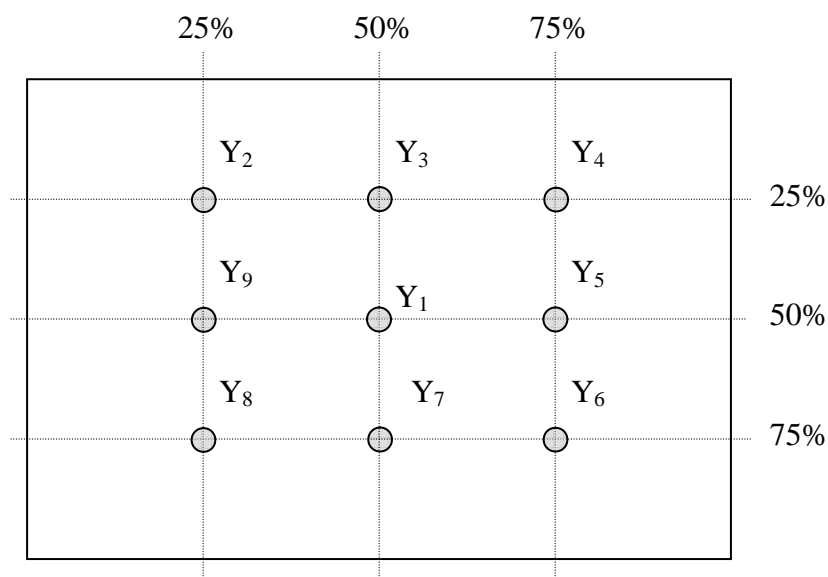

$$\text{Luminance uniformity} = \frac{(\text{Min Luminance of 9 points})}{(\text{Max Luminance of 9 points})} \times 100\%$$

Note (6) Rubbing Direction (The different Rubbing Direction will cause the different optimal view direction.)

4.0 BLOCK DIAGRAM

4.1 TFT LCD Module

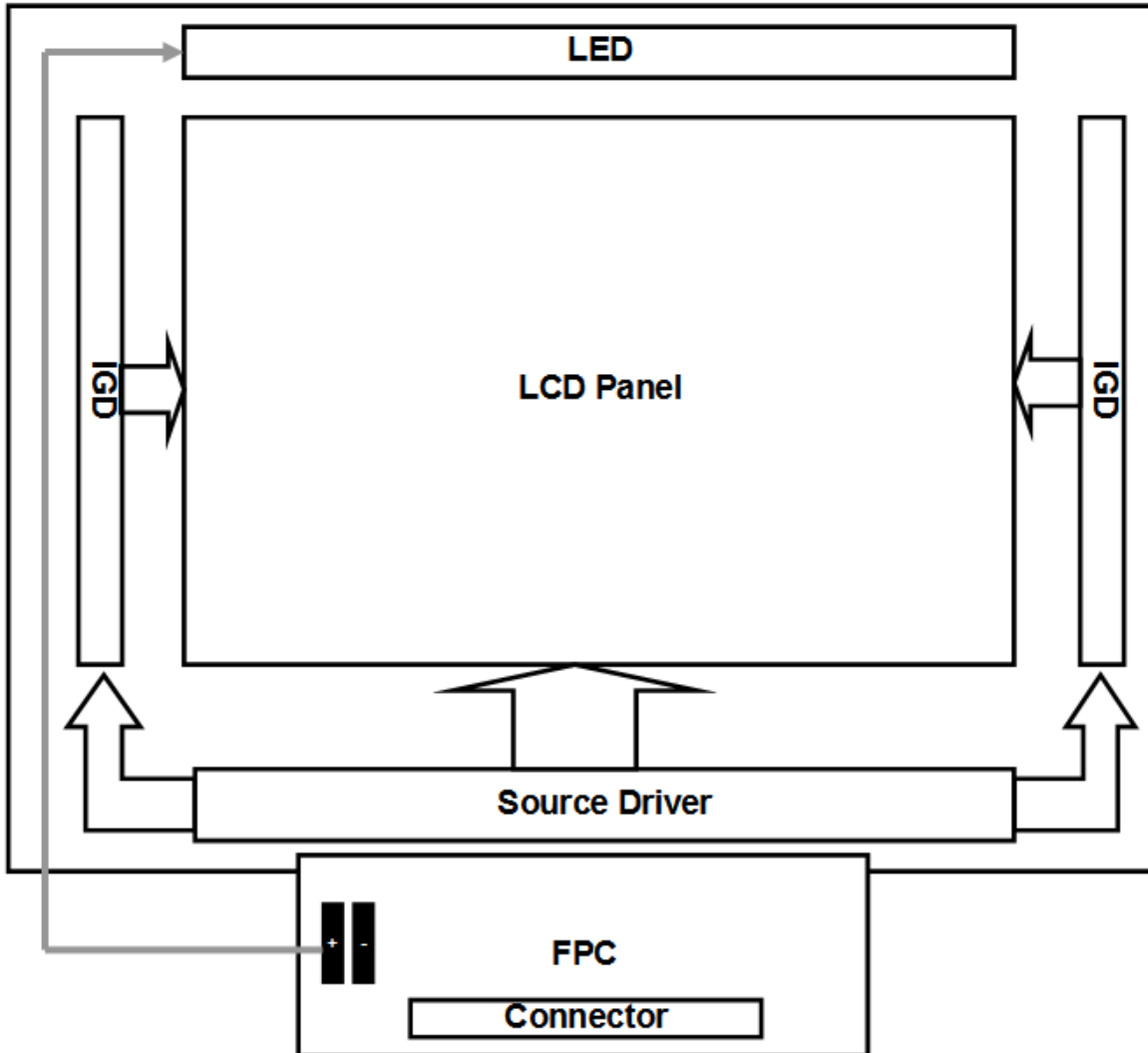

4.2 Pixel Format

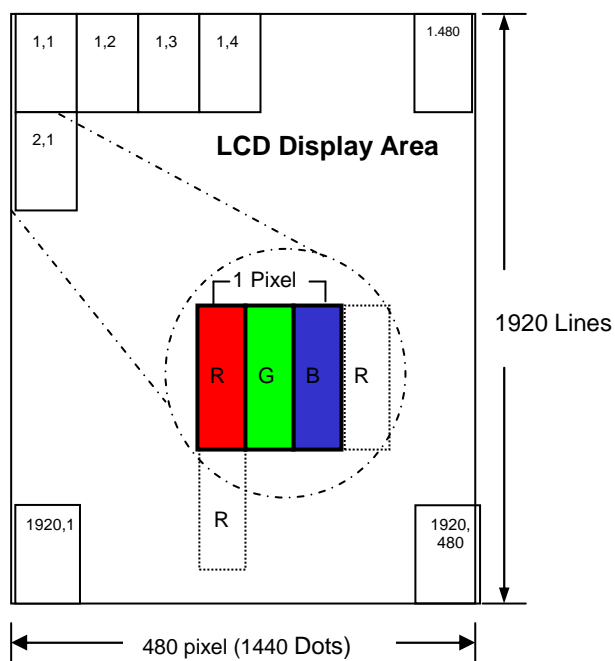

5.0 INTERFACE PIN CONNECTION

FPC connector is used for electronics interface. The recommended model is Hirose FH34SRJ-40S-0.5SH(50)

Pin No.	Symbol	I/O	Function
1	GND	P	Ground
2	NC	---	No connection
3	LED+	P	LED Anode
4	LED+	P	LED Anode
5	NC	---	No connection
6	LED-	P	LED Cathode
7	LED-	P	LED Cathode
8	NC	---	No connection
9	GND	P	Ground
10	NC	---	No connection
11	AVDD	P	Power supply for analog circuit
12	NC	---	No connection
13	VGH	P	Power supply for analog circuit
14	NC	---	No connection
15	VGL	P	Power supply for analog circuit
16	NC	---	No connection
17	GND	P	Ground
18	VCOM	P	Power supply for common voltage
19	GND	P	Ground
20	GND	P	Ground
21	RESET	I	Global reset
22	VDD	P	Power supply for digital circuits
23	STBYB	I	Standby mode
24	TP_Sync	O	Sync signal for touch panel
25	GND	P	Ground
26	D0P	I	MIPI Data Input Lane0 positive-end
27	D0N	I	MIPI Data Input Lane0 negative-end
28	GND	P	Ground
29	D1P	I	MIPI Data Input Lane1 positive-end
30	D1N	I	MIPI Data Input Lane1 negative-end
31	GND	P	Ground
32	CLKP	I	MIPI Clock Input positive-end
33	CLKN	I	MIPI Clock Input negative-end
34	GND	P	Ground
35	D2P	I	MIPI Data Input Lane2 positive-end
36	D2N	I	MIPI Data Input Lane2 negative-end
37	GND	P	Ground

38	D3P	I	MIPI Data Input Lane3 positive-end
39	D3N	I	MIPI Data Input Lane3 negtive-end
40	GND	P	Ground

6.0 ELECTRICAL CHARACTERISTICS

6.1 TFT LCD Module

Item	Symbol	Min.	Typ.	Max.	Unit	Note
Supply Voltage	VDD	3.0	3.3	3.6	V	
	VGH	17.0	18.0	19.0	V	
	VGL	-11	-10	-9	V	
	AVDD	11.8	12	12.2	V	
VCOM	VCOM	4.5	4.88	5.2	V	Note (1)
Input signal voltage	ViH	0.7 VDD	-	VDD	V	Note (2)
	ViL	0	-	0.3 VDD	V	
Current of power supply	IDD	-	-	35	mA	VDD =3.3V
	IADD	-	-	30	mA	AVDD=12V
	IGH	-	-	5	mA	VGH=18V
	IGL	-	-	-5	mA	VGL= -10V
	Ivcom	-	-	0.1	mA	Vcom= 4.88V

Note (1): Please adjust VCOM to make the flicker level minimum.

Note (2) :RESET 、STBYB

6.2 MIPI DC Characteristics

6.2.1 HS Receiver DC Specification

Parameter	Symbol	Rating			Unit	Note
		Min	Typ	Max		
Operation Voltage	VDD	1.5-10%	1.5	1.5+10%	mV	
Differential Input Voltage	VID	70	200	260	mV	
Common Mode Voltage	V _{CMRX(DC)}	70	-	330	mV	
Differential Input High Threshold Voltage	VTH	-	-	70	mV	
Differential Input Low Threshold Voltage	VTL	-70	-	-	mV	
Singled-ended input high voltage	V _{IHHS}	-	-	460	mV	
Singled-ended input low voltage	V _{ILHS}	-40	-	-	mV	
Singled-ended threshold for HS termination enable	V _{TERM-EN}	-	-	450	mV	
Differential input impedance	Z _{ID}	80	100	125	ohm	
Pin leakage current	I _{LEAK}	-10	-	10	uA	
Common-mode interference beyond 450MHz	ΔV _{CMRX(HF)}	-	-	100	mV	
Common-mode interference 50MHz - 450MHz	ΔV _{CMRX(LF)}	-50	-	50	mV	
Common-mode termination	C _{CM}	-	-	60	pF	
Embedded Termination	R _T	90	100	110	ohm	2bits RT_SEL[1: 0] for termination resistor selection 00 → 200ohm 10, 01 → 150ohm 11 → 100ohm (default) 1bit ERM _R _EN for termination resistor enable TERM _R _EN=0, termr disable R=(OPEN) TERM _R _EN=1, termr enable

Note:

- (1) Excluding possible additional RF interference of 100mV peak sine wave beyond 450MHz.
- (2) This table value includes a ground difference of 50mV between the transmitter and the receiver, the static common-mode level tolerance and variations below 450MHz.

6.2.2 LP Receiver DC Specification

Parameter	Symbol	Rating			Unit	Note
		Rating				
		Min	Typ	Max		
Logic 1 input voltage	V_{IH}	880	-	-	mV	
Logic 0 input voltage, not in ULP State	V_{IL}	-	-	550	mV	
Input hysteresis	V_{HYST}	25	-	-	mV	

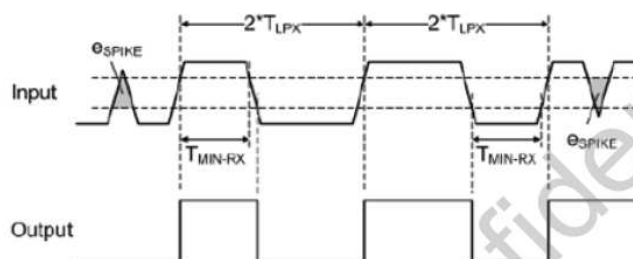

6.2.3 Line Contention Detection

Parameter	Symbol	Rating			Unit	Note
		Min	Typ	Max		
Logic 1 contention threshold	V_{IHCD}	450	-	-	mV	
Logic 0 contention threshold	V_{ILCD}	-	-	200	mV	

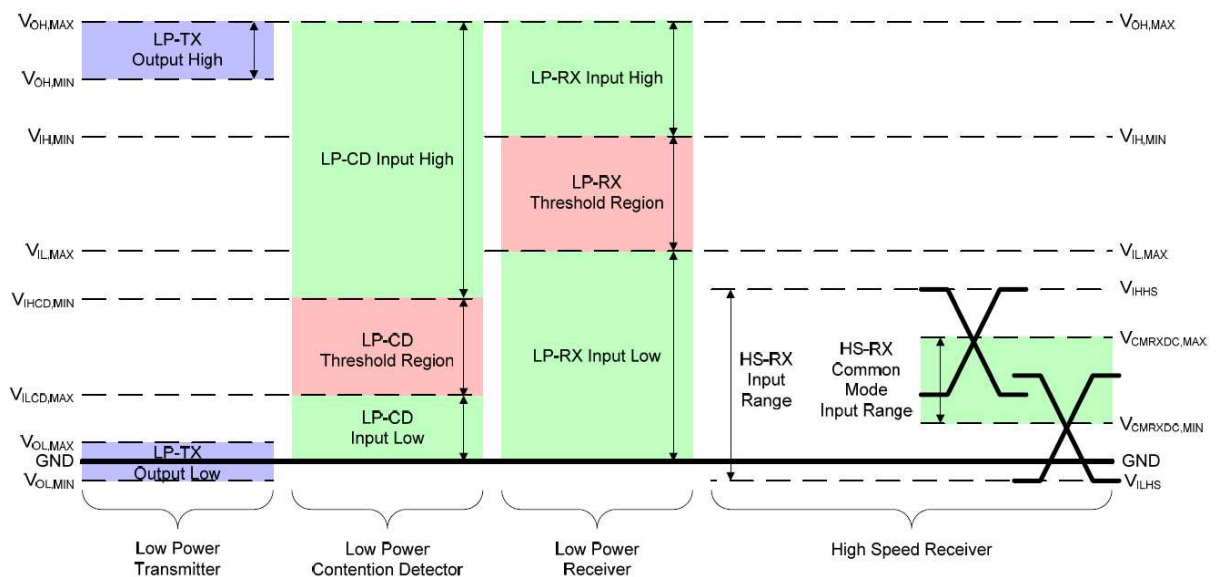

6.3 Interface Timing

Item	Symbol	Min.	Typ.	Max.	Unit
MIPI Video data rate(4 lane)	-	-	397.7	-	Mbps
PCLK Frequency	FPCLK	-	66.3	-	MHz
Horizontal Synchronization	Hsync	-	30	-	PCLK
Horizontal Back Porch	HBP	-	30	-	PCLK
Horizontal Front Porch	HFP	-	30	-	PCLK
Hsync+HBP+HFP	-	75	90	-	PCLK
Horizontal Address(Display Area)	Hadr	-	480	-	PCLK
Horizontal cycle	-	555	570	-	PCLK
Vertical Synchronization	Vsync	-	6	-	Line
Vertical Back Porch	VBP	-	6	-	Line
Vertical Front Porch	VFP	-	6	-	Line
Vsync+VBP+VFP	-	15	18	-	Line
Vertical Address(Display Area)	Vadr	-	1920	-	Line
Vertical cycle	-	1935	1938	-	Line
Frame Rate	-	-	60	-	Hz

6.4 Power On / Off Sequence

Power-On/Off Timing Sequence:

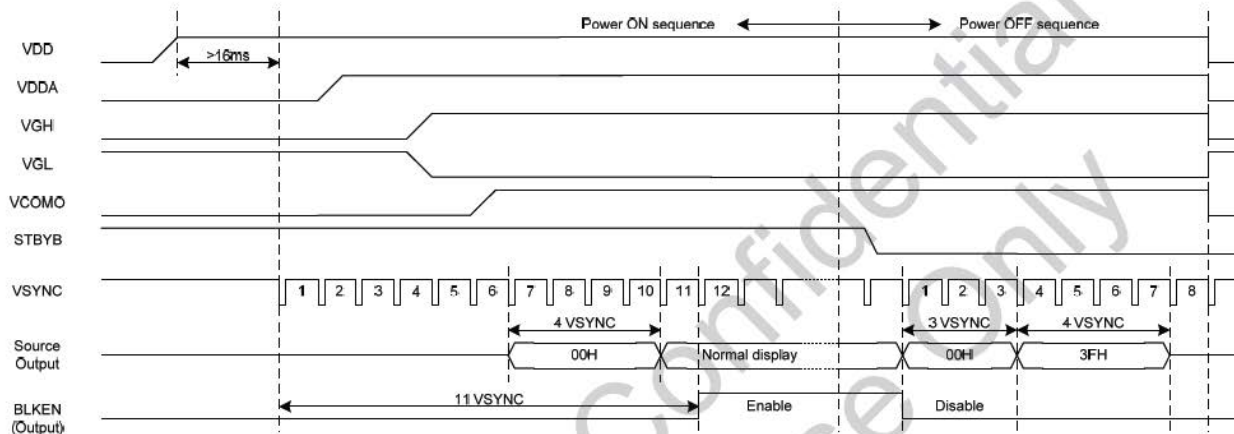

6.5 Backlight Unit

Parameter	Symbol	Min	Typ	Max	Units	Condition
LED Current	I_F	--	160	--	mA	$T_a=25^{\circ}\text{C}$
LED Voltage	V_F	2.95	--	3.55	Volt	$T_a=25^{\circ}\text{C}$
LED Life-Time	N/A	--	30,000	--	Hour	$T_a=25^{\circ}\text{C}$ $I_F=160\text{mA}$ Note (2)

Note (1) LED life time (Hr) can be defined as the time in which it continues to operate under the condition: $T_a=25\pm 3^{\circ}\text{C}$, typical IL value indicated in the above table until the brightness becomes less than 50%.

Note (2) The "LED life time" is defined as the module brightness decrease to 50% original brightness at $T_a=25^{\circ}\text{C}$ and $I_L=160\text{mA}$. The LED lifetime could be decreased if operating I_L is larger than 160mA. The constant current driving method is suggested.

Note (3) LED Light Bar Circuit

7.0 Reliability test items

No.	Item	Conditions	Remark
1	High Temperature Storage	Ta=+80°C, 240hrs	
2	Low Temperature Storage	Ta=-30°C, 240hrs	
3	High Temperature Operation	Ta=+70°C, 240hrs	
4	Low Temperature Operation	Ta=-20°C, 240hrs	
5	Thermal Cycling Test (non operation)	-20°C(30min)→+70°C(30min), 100 cycles	
6	Vibration	Sine Wave 1.5G, 5~500Hz, XYZ 30min/each direction	
7	Shock	Half-Sine, 200G, 2ms, ±XYZ, 1time	

Note: There is no display function NG issue occurred, all the cosmetic specification is judged before the reliability stress.

Storage / Operating temperature

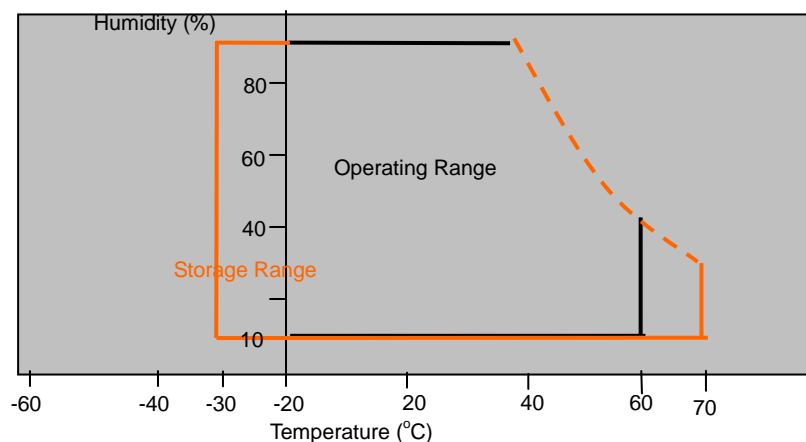

Note .Max wet bulb temp.=39°C

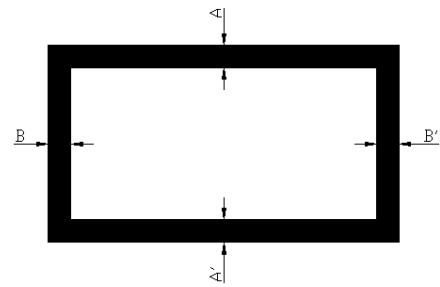
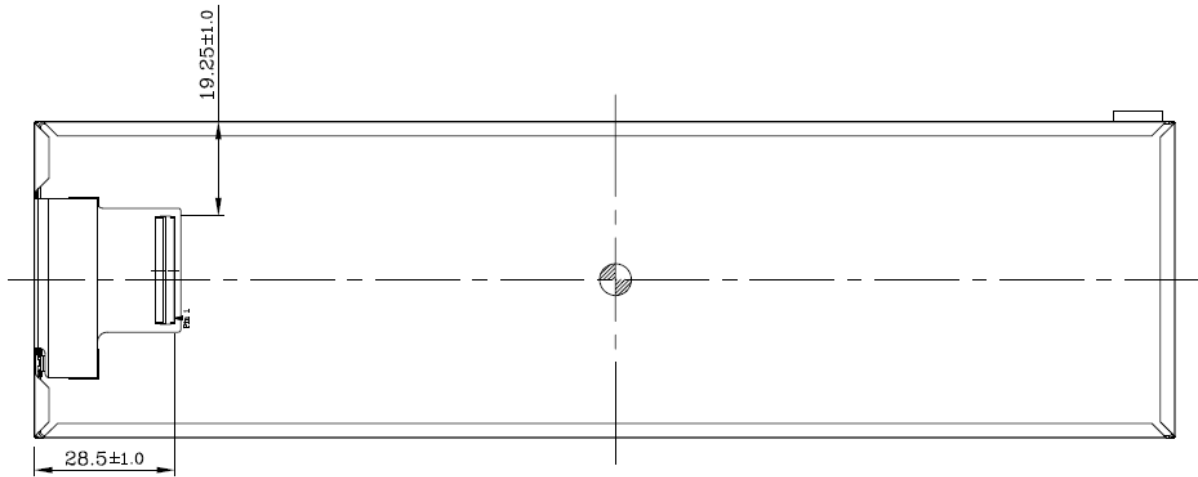

Note:
General Tolerance $\pm 0.3\text{mm}$

BM Assembly Tolerance

$$|A - A'| \leq 1 (\text{mm})$$

$$|B - B'| \leq 1 (\text{mm})$$

9 LOT MARK

9.1 Lot Mark

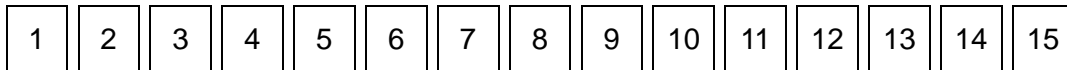

Code 1,2,3,4,5,6: HannStar internal flow control code.

Code 7: production location.

Code 8: production year.

Code 9: production month.

Code 10,11,12,13,14,15: serial number.

Note (1) Production Year

Year	2006	2007	2008	2009	2010	2011	2012	2013	2014	2015
Mark	6	7	8	9	0	1	2	3	4	5

Note (2) Production Month

Month	Jan.	Feb.	Mar.	Apr.	May.	Jun.	Jul.	Aug.	Sep.	Oct	Nov.	Dec.
Mark	1	2	3	4	5	6	7	8	9	A	B	C

9.2 Location of Lot Mark

- (1) Location: The lot mark is attached to the back side of the LCD module. See Product back view. (Section 8.0 : OUTLINE DIMENSION)
- (2) Detail of the Lot mark: Print 15 code as lot mark (see 9.1 Lot Mark)
- (3) This is subject to change without prior notice.



10.0 PACKAGE SPECIFICATION

10.1 Packing form

LCM Model	LCM Qty. in the Box	Inner Box Size(mm)	Notice
TVT0880B-I	60 pcs/box	477x310x203	

10.2 Packing assembly drawings

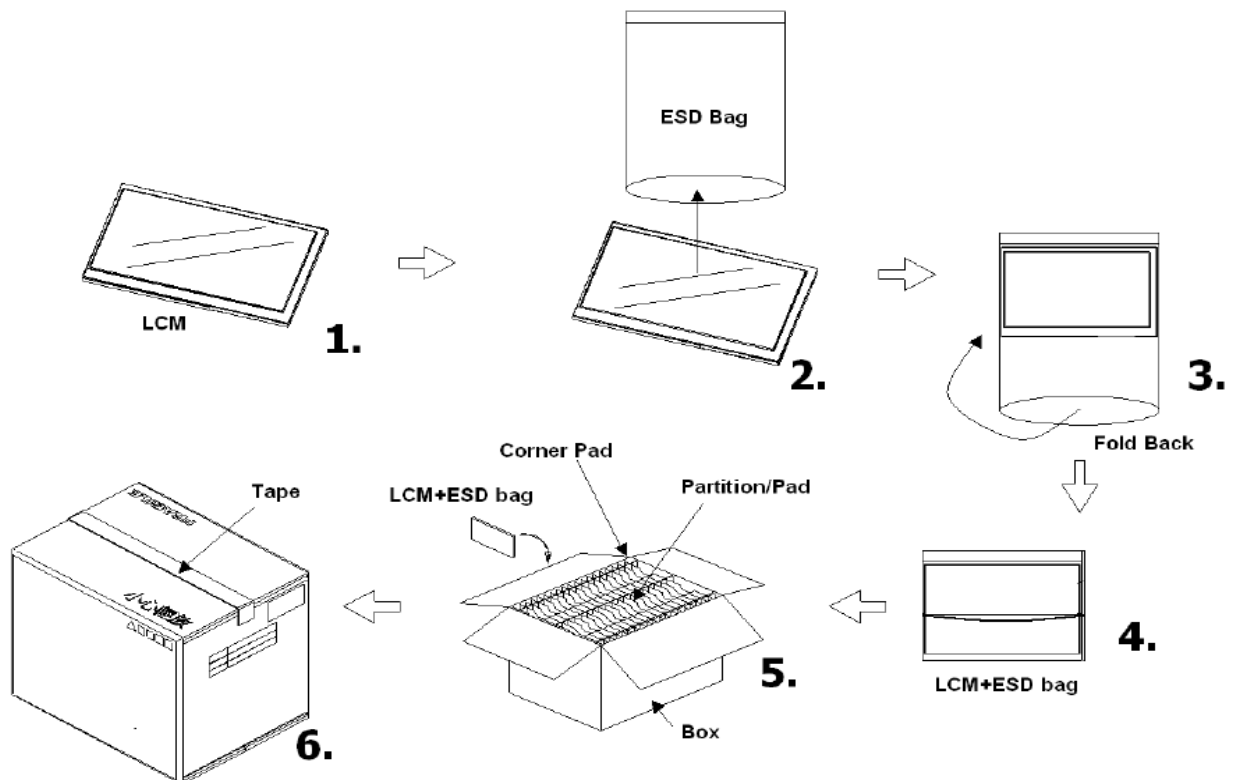

11.0 GENERAL PRECAUTION

11.1 Use Restriction

This product is not authorized for use in life supporting systems, aircraft navigation control systems, military systems and any other application where performance failure could be life-threatening or otherwise catastrophic.

11.2 Disassembling or Modification

Do not disassemble or modify the module. It may damage sensitive parts inside LCD module, and may cause scratches or dust on the display. HannStar does not warrant the module, if customers disassemble or modify the module.

11.3 Breakage of LCD Panel

11.3.1. If LCD panel is broken and liquid crystal spills out, do not ingest or inhale liquid crystal, and do not contact liquid crystal with skin.

11.3.2. If liquid crystal contacts mouth or eyes, rinse out with water immediately.

11.3.3. If liquid crystal contacts skin or cloths, wash it off immediately with alcohol and rinse thoroughly with water.

11.3.4. Handle carefully with chips of glass that may cause injury, when the glass is broken.

11.4 Electric Shock

11.4.1. Disconnect power supply before handling LCD module.

11.4.2. Do not pull or fold the LED cable.

11.4.3. Do not touch the parts inside LCD modules and the fluorescent LED's connector or cables in order to prevent electric shock.

11.5 Absolute Maximum Ratings and Power Protection Circuit

11.5.1. Do not exceed the absolute maximum rating values, such as the supply voltage variation, input voltage variation, variation in parts' parameters, environmental temperature, etc., otherwise LCD module may be damaged.

11.5.2. Please do not leave LCD module in the environment of high humidity and high temperature for a long time.

11.5.3. It's recommended to employ protection circuit for power supply.

11.6 Operation

11.6.1 Do not touch, push or rub the polarizer with anything harder than HB pencil lead.

11.6.2 Use fingerstalls of soft gloves in order to keep clean display quality, when persons handle the LCD module for incoming inspection or assembly.

11.6.3 When the surface is dusty, please wipe gently with absorbent cotton or other soft material.

11.6.4 Wipe off saliva or water drops as soon as possible. If saliva or water drops contact with polarizer for a long time, they may causes deformation or color fading.

11.6.5 When cleaning the adhesives, please use absorbent cotton wetted with a little petroleum benzine or other adequate solvent.

11.7 Mechanism

Please mount LCD module by using mounting holes arranged in four corners tightly.

11.8 Static Electricity

11.8.1 Protection film must remove very slowly from the surface of LCD module to prevent from electrostatic occurrence.

11.8.2 Because LCD module use CMOS-IC on circuit board and TFT-LCD panel, it is very weak to electrostatic discharge. Please be careful with electrostatic discharge. Persons who handle the module should be grounded through adequate methods.

11.9 Strong Light Exposure

The module shall not be exposed under strong light such as direct sunlight. Otherwise, display characteristics may be changed.

11.10 Disposal

When disposing LCD module, obey the local environmental regulations.

Note

訊號掃描注意事項



屏正放時 在 480RGB X1920 解析度下,Data訊號只支援 1 種掃描方向
 我司採用此設計

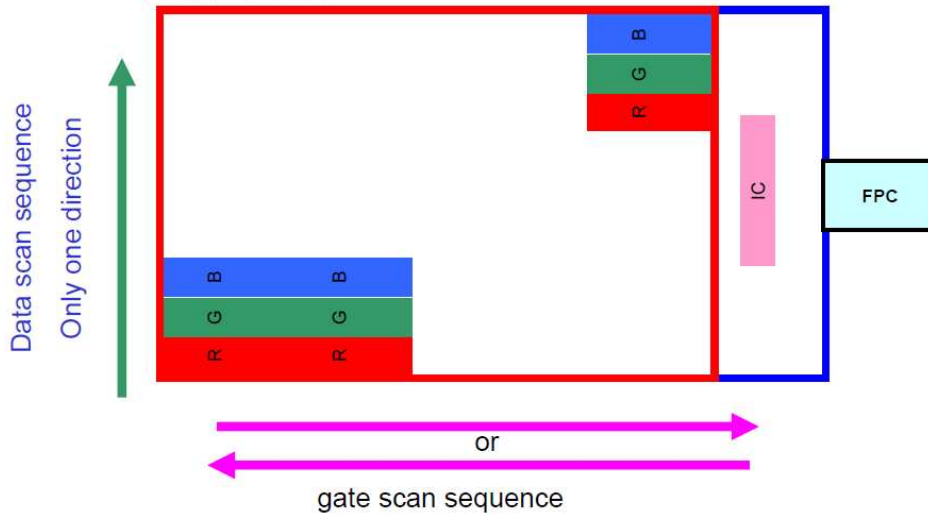

訊號掃描注意事項



屏倒放時 在 480RGB X1920 解析度下,Data訊號 只支援 1 種掃描方向
 gate scan sequence



需透過MIPI下Code做變更