



Product Specification

Part Name: 3inch TFT Display Module

Customer Part ID:

Topovision Part ID: TVT0300C-T

Ver: A

Customer:
Approved by

From: Topovision Technology Co., Ltd.
Approved by

Sales@topo-vision.com

Notes:

1. Please contact Topovision Technology Co., Ltd. before assigning your product based on this module specification
2. The information contained herein is presented merely to indicate the characteristics and performance of our products. No responsibility is assumed by Topovision Technology Co., Ltd. for any intellectual property claims or other problems that may result from application based on the module described herein.

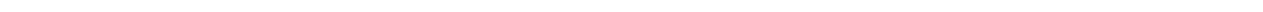

Table of Contents

Coversheet.....	1
Table of Contents	2
Record of Revision.....	3
1 General specifications.....	4
2 Input/Output terminals.....	5
3 Absolute maximum ratings.....	7
4 LCD module electrical characteristics.....	7
5 AC ELECTRICAL CHARACTERISTICS	9
5.1 CPU interface mode	9
5.2 Reset Timing.....	12
6 POWER ON/OFF SEQUENCE.....	13
7 Optical characteristics	15
8 Environmental / Reliability tests	19
9 Mechanical drawing	20
10 Packing drawing	21
11 Precautions for use of LCD modules	22

Record of Revision

Rev	Issued Date	Description
A	2010-11-08	Final Product Specification

1 General specifications

Feature		Spec
Display Spec.	Size	3.0 inch
	Resolution	240(RGB) X 400
	Interface	RGB+3SPI/CPU
	Color Depth	262K
	Technology type	a-si TFT
	Pixel pitch (mm)	0.162x0.162
	Pixel Configuration	R.G.B. Vertical Stripe
	Display Mode	ECB Mode Transflective
	Surface Treatment(Up Polarizer)	Clear type (3H)
	Surface Treatment(TSP)	Without TSP
	Viewing Direction	12 o'clock
	Gray Scale Inversion Direction	6 o'clock
Mechanical Characteristics	DIM. LCM (W x H x D) (mm)	47.28x76.4x2.4
	Active Area(mm)	38.88x 64.8
	With /Without TSP	Without TSP
	Weight (gram)	18.25g
	LED Numbers	4LEDs (serial)

Note 1 : Viewing direction for best image quality is different from TFT definition, there is a 180 degree shift.

Note 2 : Requirements on Environmental Protection: Q/S0002

2 Input/Output terminals

Pin	Symbol (CPU)	Symbol (RGB)	I/O	Description	Remark
1	GND	GND		Ground	
2	LED-K	LED-K		Power supply for LED(Low voltage)	
3	LED-A2	LED-A2		Power supply for LED(High voltage2)	
4	LED-A1	LED-A1		Power supply for LED(High voltage1)	
5	GND	GND		Ground	
6	GND	GND		Ground	
7	/RESET	/RESET	I	RESET serial(Low active)	
8	GND	GND		Ground	
9	DB17	R5	I/O	CPU:Data bus serial(MSB) RGB:RED data signal(MSB)	
10	DB16	R4	I/O	CPU:Data bus serial RGB:RED data signal	
11	DB15	R3	I/O	CPU:Data bus serial RGB:RED data signal	
12	DB14	R2	I/O	CPU:Data bus serial RGB:RED data signal	
13	DB13	R1	I/O	CPU:Data bus serial RGB:RED data signal	
14	DB12	R0	I/O	CPU:Data bus serial RGB:RED data signal(LSB)	
15	DB11	G5	I/O	CPU:Data bus serial RGB:GREEN data signal(MSB)	
16	DB10	G4	I/O	CPU:Data bus serial RGB:GREEN data signal	
17	DB9	G3	I/O	CPU:Data bus serial RGB:GREEN data signal	
18	DB8	G2	I/O	CPU:Data bus serial RGB:GREEN data signal	
19	DB7	G1	I/O	CPU:Data bus serial RGB:GREEN data signal	
20	DB6	G0	I/O	CPU:Data bus serial RGB:GREEN data signal(LSB)	
21	DB5	B5	I/O	CPU:Data bus serial RGB:BLUE data signal(MSB)	
22	DB4	B4	I/O	CPU:Data bus serial RGB:BLUE data signal	
23	DB3	B3	I/O	CPU:Data bus serial RGB:BLUE data signal	
24	DB2	B2	I/O	CPU:Data bus serial RGB:BLUE data signal	
25	DB1	B1	I/O	CPU:Data bus serial RGB:BLUE data signal	
26	DB0	B0	I/O	CPU:Data bus serial RGB:BLUE data signal(LSB)	

27	GND	SDI	I	CPU: Ground RGB: Serial data input pin	
28	OPEN	SDO	O	CPU: not use. leave open or to GND/VCCIO RGB: Serial data output pin	
29	/RD	NC	I	CPU: read signal and read data. RGB: NO connect	
30	/WR	SCL	I	CPU: write signal and write data. RGB: Serial Clock signal	
31	RS	NC	I	CPU: Data / Command Selection pin. RGB: NO connect	
32	/CS	CS	I	Chip select signal.	
33	GND	ENABLE	I	CPU: Ground RGB: A data ENABLE signal	
34	GND	VSYNC	I	CPU: Ground RGB: Frame synchronizing signal	
35	GND	HSYNC	I	CPU: Ground RGB: Frame synchronizing signal	
36	GND	DOTCLK	I	CPU: Ground RGB: Pixel clock signal	
37	TE	TE	O	CPU: Tearing effect output. RGB: Not used, please open this pin.	
38	VCCIO	VCCIO	P	I/O Pad and Digital power supply	
39	VCC	VCC	P	Analog power supply	
40	IM0/1D	IM0/1D	I	System interface select.	
41	IM1	IM1	I	System interface select.	
42	IM2	IM2	I	System interface select.	
43	GND	GND		Ground	
44	GND	GND		Ground	
45	GND	GND		Ground	

Note1: P: Power/GND; I: input pin; O: output

3 Absolute maximum ratings

Item	Symbol	MIN	MAX	Unit	Remark
Supply Voltage	VCC	-0.3	4.6	V	
Supply Voltage	VCCIO	-0.3	4.6	V	
Input voltage	D[17: 0], CS, RD, WR, RS/SCL, SDI, VSYNC, HSYNC, DOTCLK, ENABLE, BS[2:0]	-0.3	VCC+0.3	V	
Back Light Forward Current	I_{LED}		25	mA	For each LED
Operating Temperature	T_{OPR}	-20	70	°C	
Storage Temperature	T_{STG}	-30	80	°C	

(GND=0, Ta = 25°C)

4 LCD module electrical characteristics

4.1 Driving TFT LCD Panel

Item	Symbol	MIN	TYP	MAX	Unit	Remark
Supply Voltage	VCC	2.5	2.8	3.3	V	
Supply Voltage	IOVCC	1.65	2.8	3.3	V	
Input Signal Voltage	Low Level	V_{IL}	-0.3	0.2* IOVCC	V	
	High Level	V_{IH}	0.8* IOVCC	IOVCC	V	
Output Signal Voltage	Low Level	V_{OL}	-0.3	0.3* IOVCC	V	
	High Level	V_{OH}	0.7* IOVCC	IOVCC	V	
(Panel+LSI) Power Consumption	Black Mode (60Hz)		TBD		mW	
	8 color Mode		TBD		mW	
	Standby Mode		TBD		mW	

(GND=0, Ta=25°C)

4.2 Backlight Unit Driving Condition

(GND=0, Ta=25°C)

Parameter	Symbol	MIN	TYP	MAX	Unit	Remark
Forward Current	I_F	-	20	-	mA	Note 1
Forward Voltage	V_F	-	12.8	-	V	Note 2
Backlight Power	W_{BL}	-	256	-	mW	

Note 1 : The LED driving condition is defined for each LED module.

Note 2: Backlight unit driving must depend on Forward Current setting.

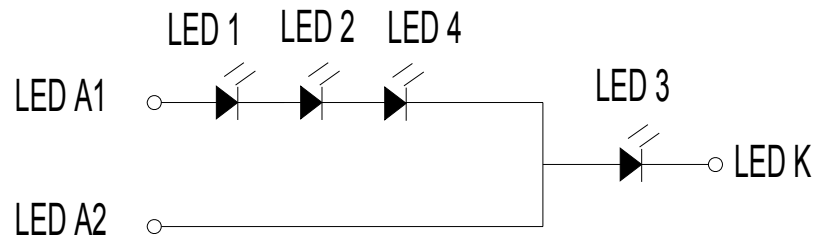
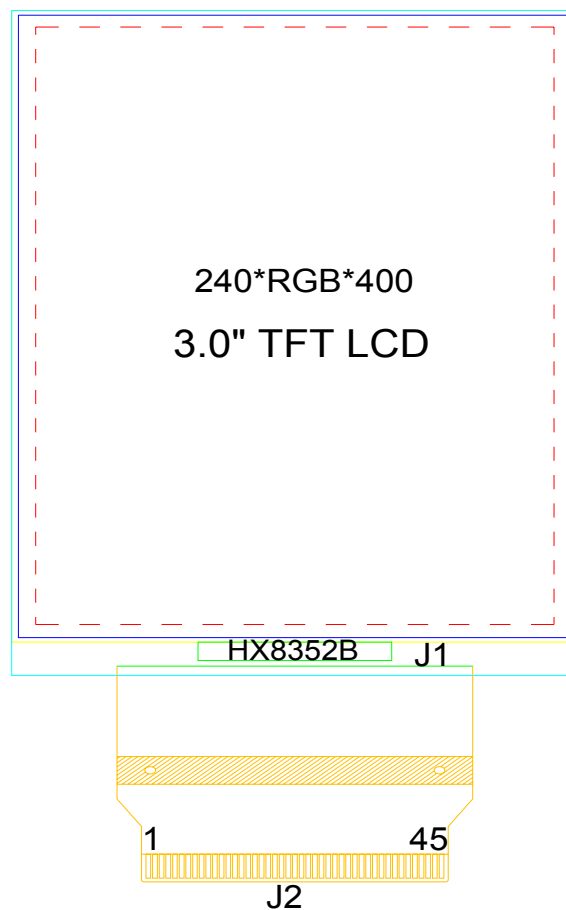

Fig.4-1 LED connection of backlight

4.3 Block Diagram



5 AC ELECTRICAL CHARACTERISTICS

5.1 CPU interface mode

5.1.1 CPU Interface Characteristics

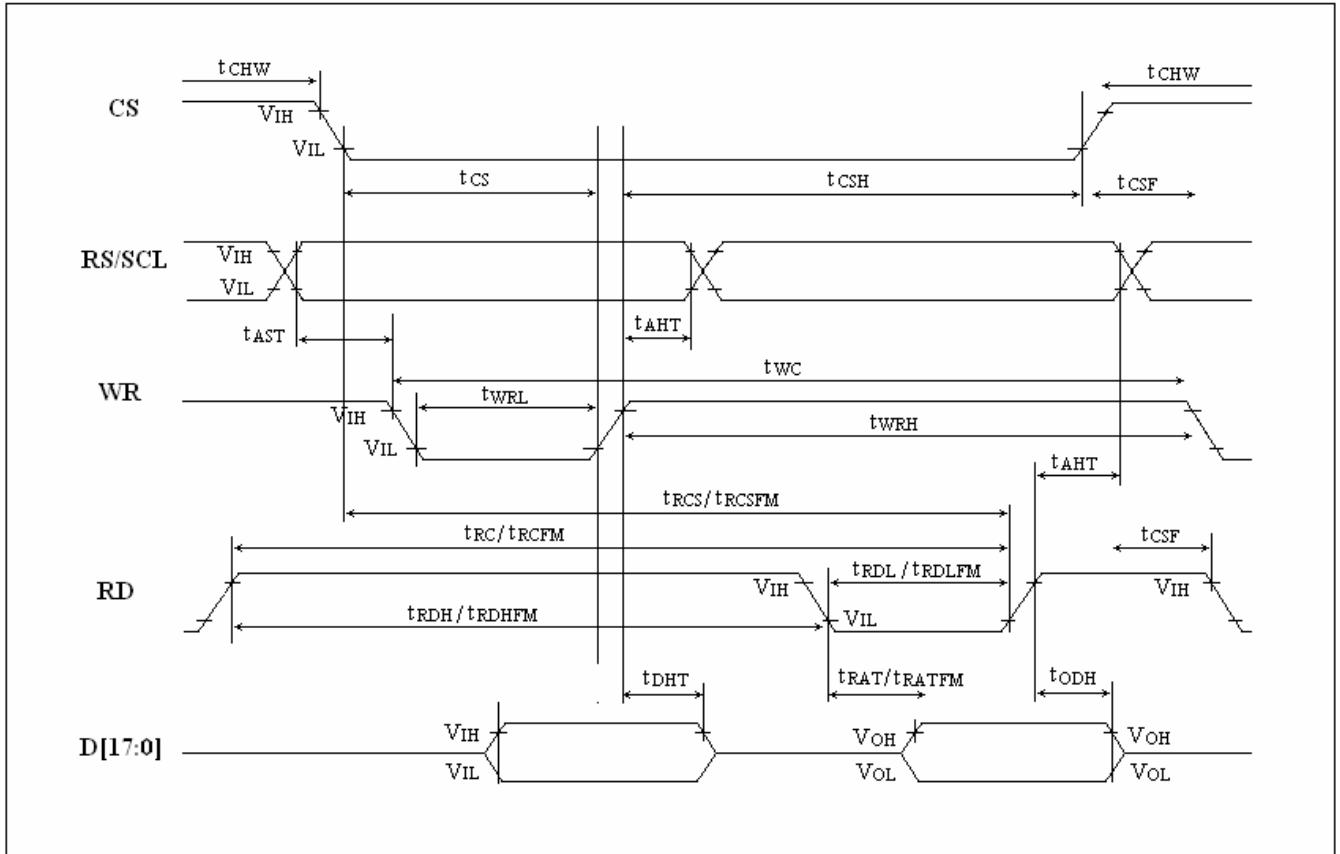

CPU Interface Characteristics

5.1.2 CPU Interface Timing Parameters

Normal Write Mode (IOVCC=1.65~3.3V, VCC=2.3~3.3V)

Signal	Symbol	Parameter	Spec.			Description
			Min.	Max.	Unit	
RS/SCL	t_{AST}	Address setup time	10	-	ns	-
	t_{AHT}	Address hold time(Write/Read)	10	-		
CS	t_{CHW}	Chip select "H" pulse width	0	-	ns	-
	t_{CS}	Chip select setup time (Write)	35	-		
	t_{RCS}	Chip select setup time (Read ID)	100	-		
	t_{RCSFM}	Chip select setup time (Read FM)	100	-		
	t_{CSF}	Chip select wait time(Write/Read)	10	-		
	t_{CSH}	Chip select hold time	10	-		
WR	t_{WC}	Write cycle	100	-	ns	-
	t_{WRH}	Control pulse "H" duration	20	-		
	t_{WRL}	Control pulse "L" duration	20	-		
RD	t_{RC}	Read cycle (ID)	150	-	ns	When read ID data
	t_{RDH}	Control pulse "H" duration (ID)	40	-		
	t_{RDL}	Control pulse "L" duration (ID)	50	-		
RD	t_{RCFM}	Read cycle (FM)	250	-	ns	When read from frame memory
	t_{RDHFM}	Control pulse "H" duration (FM)	50	-		
	t_{RDLFM}	Control pulse "L" duration (FM)	150	-		
D[17:0]	t_{DST}	Data setup time	20	-	ns	For maximum $C_L=30\text{pF}$ For minimum $C_L=8\text{pF}$
	t_{DHT}	Data hold time	20	-		
	t_{RAT}	Read access time (ID)	-	70		
	t_{RATFM}	Read access time (FM)	-	100		
	t_{ODH}	Output disable time	20	80		

CPU Interface Timing Parameters

5.1.3 CPU Interface Register write/read timing

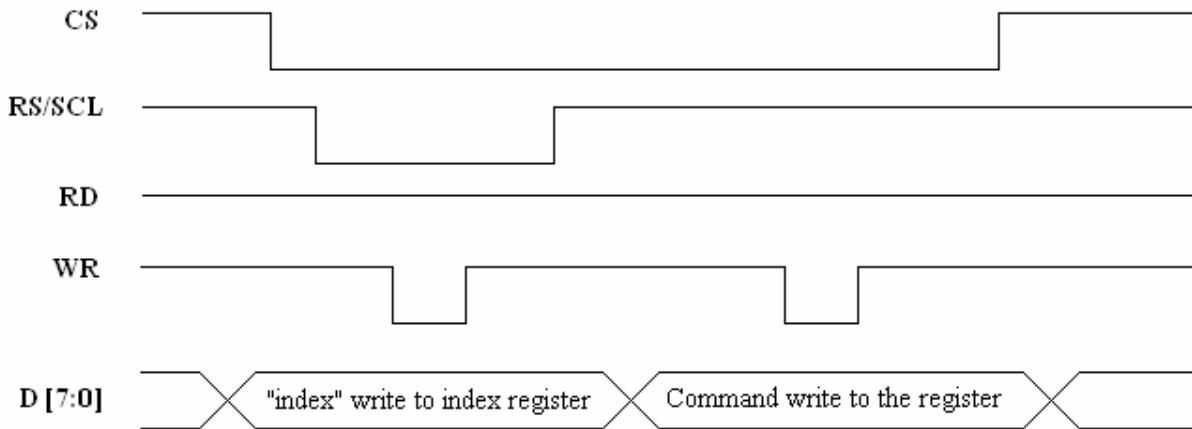

System Bus Interface Write Register Timing

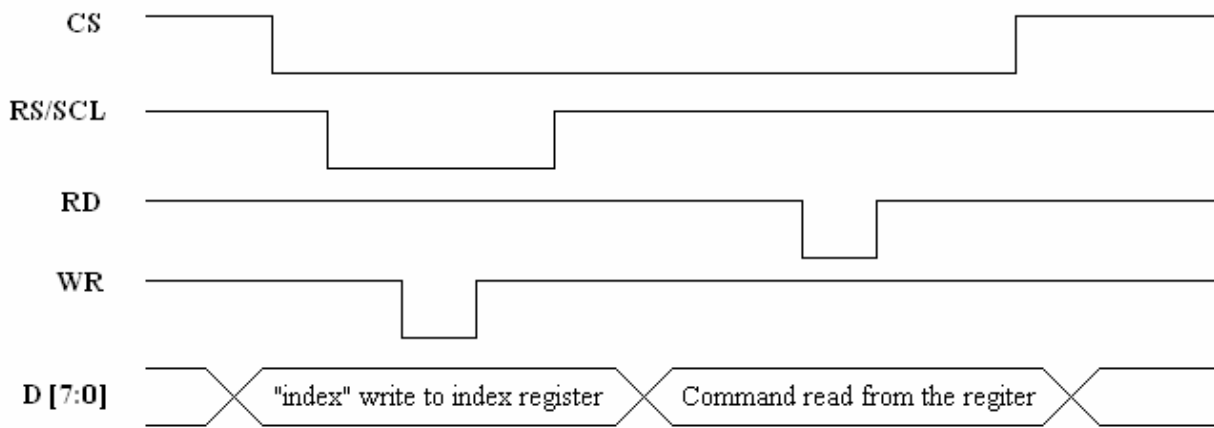

System Bus Interface Read Register Timing

5.2 Reset Timing

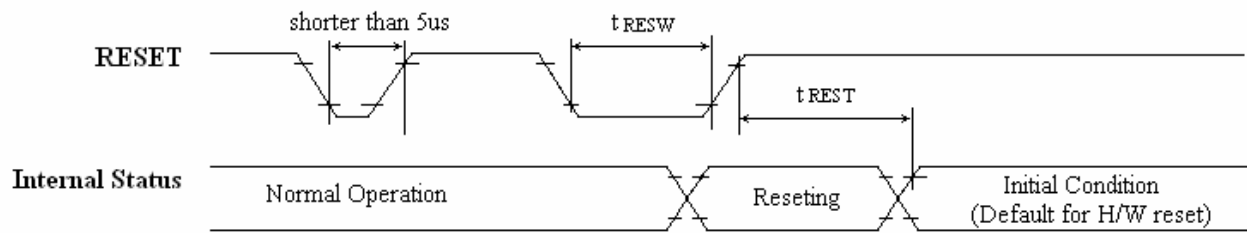

Reset timing

Reset input timing

Symbol	Parameter	Related Pins	Spec.			Note	Unit
			Min.	Typ.	Max.		
t_{RESW}	Reset low pulse width	RESET	10	-	-	-	us
t_{REST}	Reset complete time	-	-	-	5	When reset applied during "Sleep In mode"	ms
		-	-	-	120	When reset applied during "Sleep Out mode"	ms

6 POWER ON/OFF SEQUENCE

6.1 POWER ON SEQUENCE

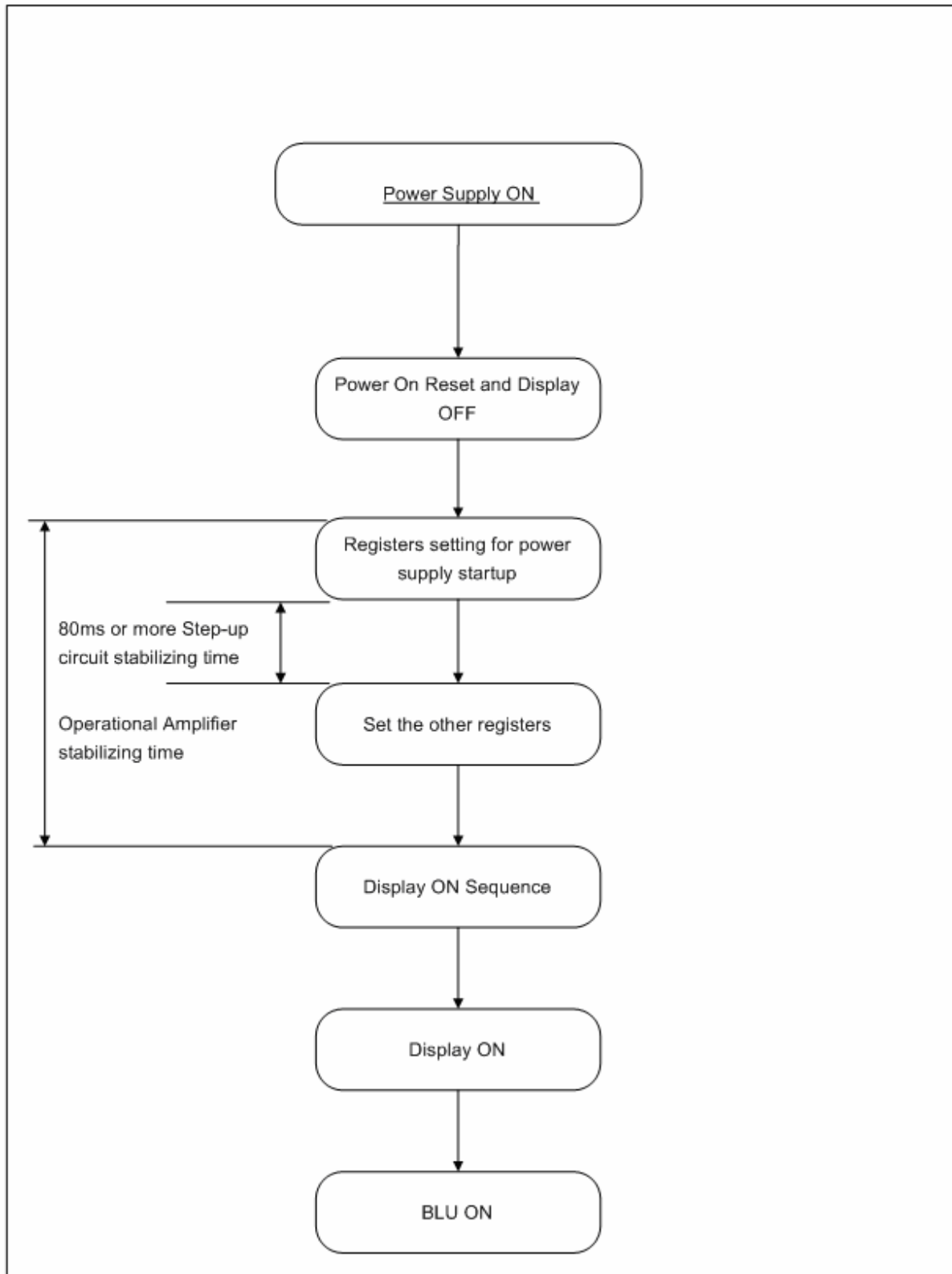

6.2 POWER OFF

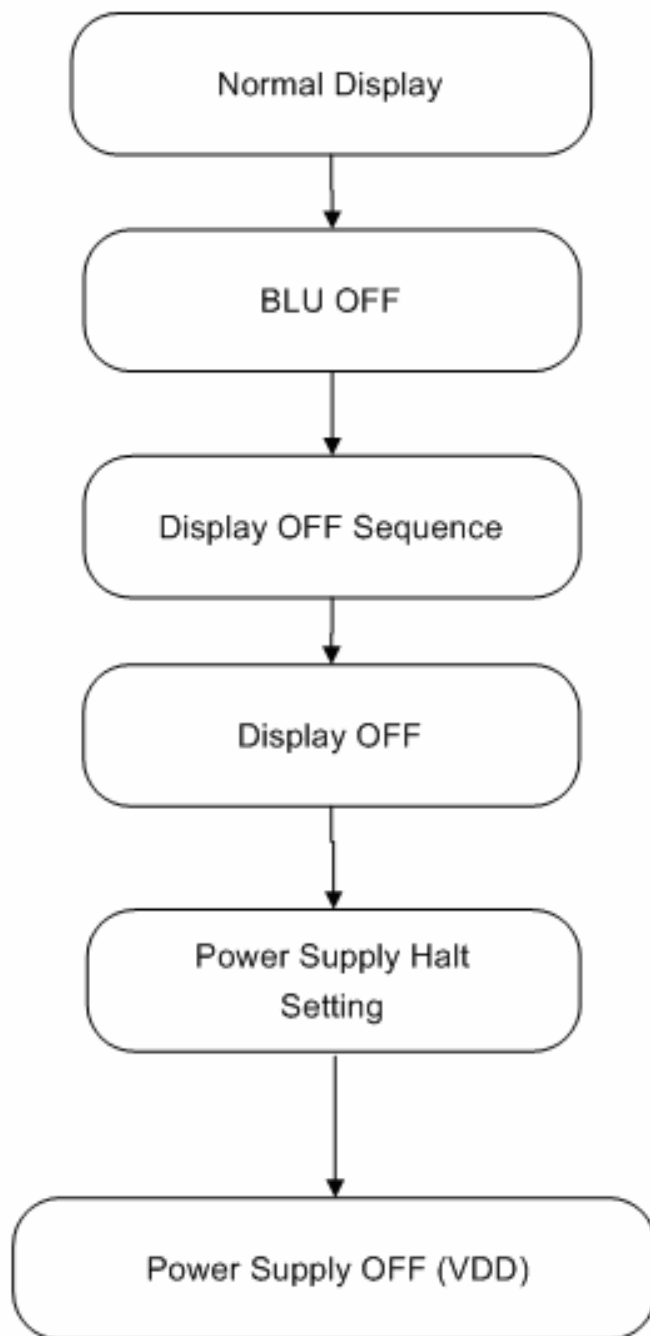

7 Optical characteristics

7.1 Driving the backlight condition

 $T_a=25^{\circ}\text{C}$

Item	Symbol	Condition	Min	Typ.	Max.	Unit	Remark
View Angles	θT	$CR \geq 10$	-	55	60	Degree	Note 2
	θB		-	40	45		
	θL		-	40	45		
	θR		-	45	50		
Contrast Ratio	CR	$\theta = 0^{\circ}$	80	100	-		Note1 Note3
Response Time	Ton	25°C	-	35	-	ms	Note1 Note4
	Toff						
Chromaticity	White	$\theta = 0^{\circ}$	-	0.30	-		Note5, Note1
			-	0.33	-		
Luminance	L		110	130	-	cd/m ²	Note1 Note7

7.2 Not Driving the backlight condition

 $T_a=25^{\circ}\text{C}$

Item	Symbol	Condition	Min	Typ.	Max.	Unit	Remark
View Angles	θT	$CR \geq 10$		60	-	Degree	Note 2
	θB		-	60	-		
	θL		-	55	-		
	θR		-	60	-		
Contrast Ratio	CR	$\theta = 0^{\circ}$	-	8	-		Note1 Note3
Response Time	Ton	25°C	-	25	-	ms	Note1 Note4
	Toff						
Chromaticity	White	$\theta = 0^{\circ}$	-	0.32	-		Note5, Note1
			-	0.34	-		
Luminance	L		110	130	-	cd/m ²	Note1 Note7
Reflection ratio				6.85%			

Test Conditions:

- VDD=2.8V, $I_L=20\text{mA}$ (LED current), the ambient temperature is 25°C .
- The test systems refer to Note 1 , Note 2 and Note 8.

Note 1: Definition of optical measurement system.

The optical characteristics should be measured in dark room. After 5 minutes operation, the optical properties are measured at the center point of the LCD screen. All input terminals LCD panel must be ground when measuring the center area of the panel.

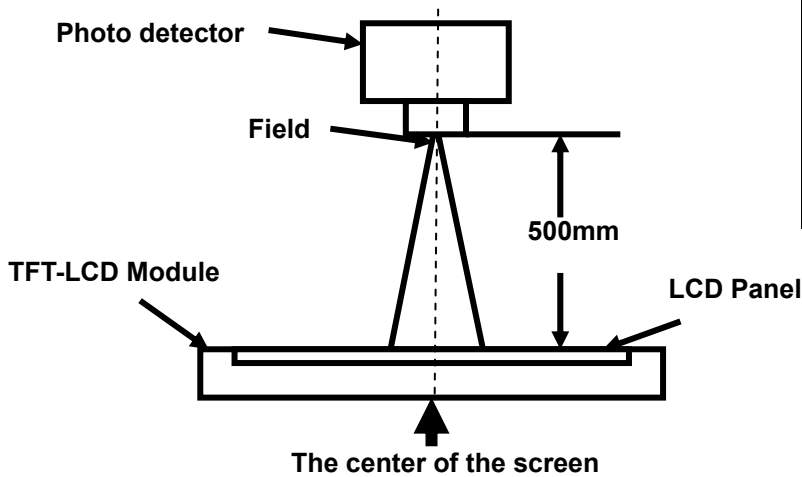

Item	Photo detector	Field
Contrast Ratio	SR-3A	1°
Luminance		
Chromaticity		
Lum Uniformity		
Response Time	BM-7A	2°

Note 2: Definition of viewing angle range and measurement system.

viewing angle is measured at the center point of the LCD by CONOSCOPE(ergo-80).

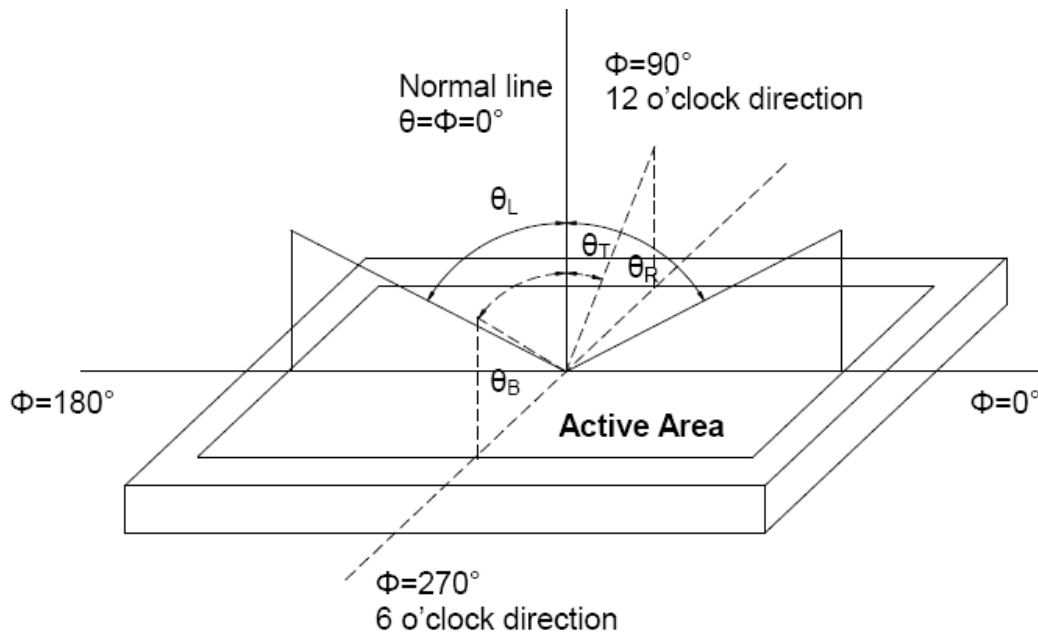

Fig. 1 Definition of viewing angle

Note 3: Definition of contrast ratio

$$\text{Contrast ratio (CR)} = \frac{\text{Luminance measured when LCD is on the "White" state}}{\text{Luminance measured when LCD is on the "Black" state}}$$

“White state “:The state is that the LCD should driven by V_{white} .

“Black state”: The state is that the LCD should driven by V_{black} .

V_{white} : To be determined V_{black} : To be determined.

Note 4: Definition of Response time

The response time is defined as the LCD optical switching time interval between “White” state and “Black” state. Rise time (T_{ON}) is the time between photo detector output intensity changed from 90% to 10%. And fall time (T_{OFF}) is the time between photo detector output intensity changed from 10% to 90%.

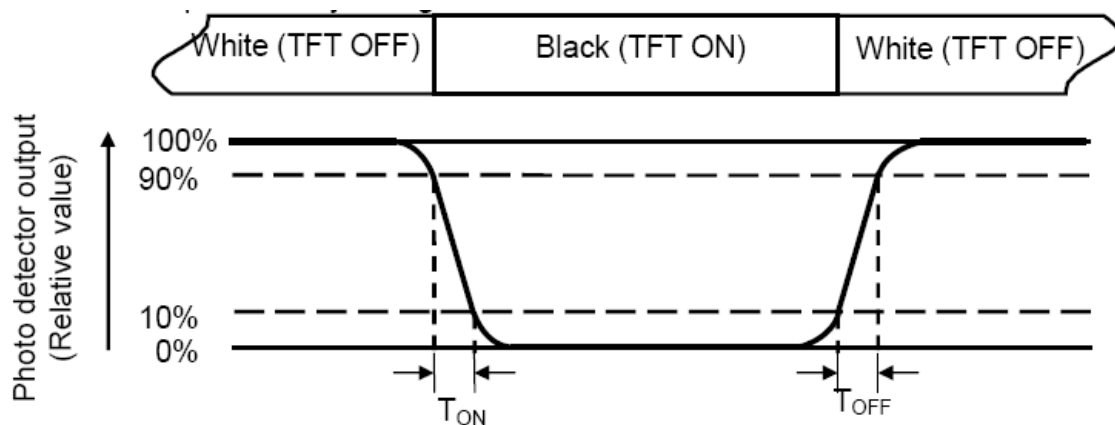

Note 5: Definition of color chromaticity (CIE1931)

Color coordinates measured at center point of LCD.

Note 6: Definition of Luminance Uniformity

Active area is divided into 9 measuring areas (Refer Fig. 2). Every measuring point is placed at the center of each measuring area.

$$\text{Luminance Uniformity}(U) = L_{\min} / L_{\max}$$

L-----Active area length W----- Active area width

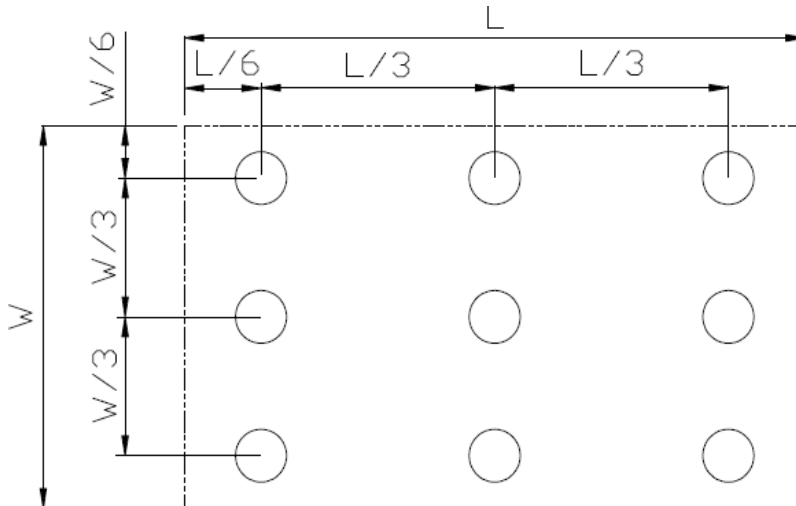

Fig. 2 Definition of uniformity

L_{\max} : The measured maximum luminance of all measurement position.

L_{\min} : The measured minimum luminance of all measurement position.

Note 7: Definition of Luminance :

Measure the luminance of white state at center point.

Note 8: Definition of Reflectance measurement system

Note 5) Reflectance is defined as follows:

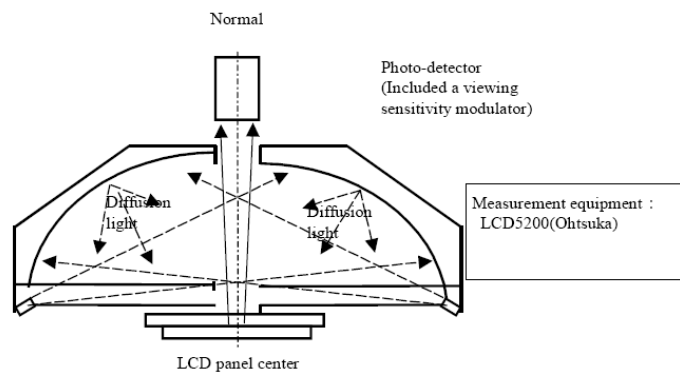

8 Environmental / Reliability tests

No	Test Item	Condition	Remarks
1	High Temperature Operation	Ts=+70°C, 240hrs	Note1 IEC60068-2-2,GB2423.2
2	Low Temperature Operation	Ta=-20°C, 240hrs	IEC60068-2-GB2423.1
3	High Temperature Storage	Ta=+80°C, 240hrs	IEC60068-2-2 GB2423.2
4	Low Temperature Storage	Ta=-30°C, 240hrs	IEC60068-2-1 GB2423.1
5	High Temperature & High Humidity Storage	+40°C, 90% RH max,240 hours	Note2 IEC60068-2-78 GB/T2423.3
6	Thermal Shock (Non-operation)	-30°C 30 min~+70°C 30 min, Change time:5min, 20 Cycle	Start with cold temperature, End with high temperature, IEC60068-2-14,GB2423.22
7	Electro Static Discharge (Operation)	C=150pF, R=330Ω · 5points/panel Air:± 8KV, 5times; Contact:± 4KV, 5 times; (Environment: 15°C ~ 35°C, 30%~60%, 86Kpa~106Kpa)	IEC61000-4-2 GB/T17626.2
8	Vibration (Non-operation)	Frequency range:10~55Hz, Stroke:1.5mm Sweep:10Hz~55Hz~10Hz 1 hours for each direction of X.Y.Z.(3 hours for total)	IEC60068-2-6 GB/T2423.10
9	Shock (Non-operation)	60G 6ms, ± X,± Y,± Z 3times for each direction	IEC60068-2-27 GB/T2423.5
10	Package Drop Test	Height:80 cm, 1 corner, 3 edges, 6 surfaces	IEC60068-2-32 GB/T2423.8

Note1: Ts is the temperature of panel's surface.

Note2: Ta is the ambient temperature of sample.

10 Packing drawing

No	Item	Model (Material)	Dimensions(mm)	Unit Weight(Kg)	Quantity	Remark	
1	LCM module	TVT0300C-T	47.28x76.40 x2.40	0.01825	420		
2	Tray	PET(Transmit)	485 x330 x13.8	0.170	24	Anti-static	
3.	EPE	EPE	485 x330 x5	0.183	3		
4	Anti-static bag	PE	700x545	0.046	1		
5	BOX	Corrugated Paper	520x345x70	0.3879	3		
6	Desiccant	Desiccant	45 x35	0.002	6		
7	Carton	Corrugated Paper	530x351x226	1.01	1		
8	Total weight	15.25±5%					

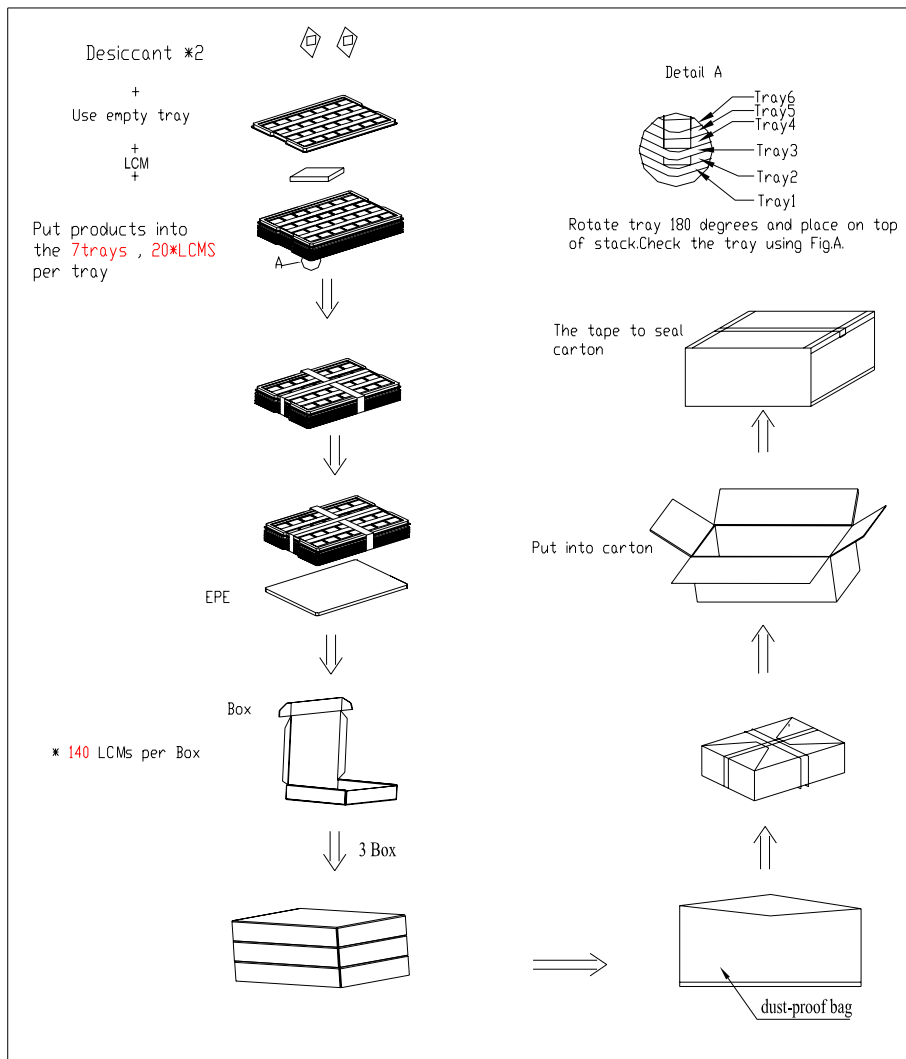

11 Precautions for use of LCD modules

11.1 Handling Precautions

- 11.1.1 The display panel is made of glass. Do not subject it to a mechanical shock by dropping it from a high place, etc.
- 11.1.2 If the display panel is damaged and the liquid crystal substance inside it leaks out, be sure not to get any in your mouth, if the substance comes into contact with your skin or clothes, promptly wash it off using soap and water.
- 11.1.3 Do not apply excessive force to the display surface or the adjoining areas since this may cause the color tone to vary.
- 11.1.4 The polarizer covering the display surface of the LCD module is soft and easily scratched. Handle this polarizer carefully.
- 11.1.5 If the display surface is contaminated, breathe on the surface and gently wipe it with a soft dry cloth. If still not completely clear, moisten cloth with one of the following solvents:
 - Isopropyl alcohol、
 - Ethyl alcoholSolvents other than those mentioned above may damage the polarizer. Especially, do not use the following:
 - Water
 - Ketone
 - Aromatic solvents
- 11.1.6 Do not attempt to disassemble the LCD Module.
- 11.1.7 If the logic circuit power is off, do not apply the input signals.
- 11.1.8 To prevent destruction of the elements by static electricity, be careful to maintain an optimum work environment.
 - 11.1.8.1 Be sure to ground the body when handling the LCD Modules.
 - 11.1.8.2 Tools required for assembly, such as soldering irons, must be properly ground.
 - 11.1.8.3 To reduce the amount of static electricity generated, do not conduct assembly and other work under dry conditions.
 - 11.1.8.4 The LCD Module is coated with a film to protect the display surface. Be care when peeling off this protective film since static electricity may be generated.

11.2 Storage precautions

- 11.2.1 When storing the LCD modules, avoid exposure to direct sunlight or to the light of fluorescent lamps.
- 11.2.2 The LCD modules should be stored under the storage temperature range. If the LCD modules will be stored for a long time, the recommend condition is:
Temperature : 0°C ~ 40°C Relatively humidity: ≤80%
- 11.2.3 The LCD modules should be stored in the room without acid, alkali and harmful gas.

11.3 Transportation Precautions:

The LCD modules should be no falling and violent shocking during transportation, and also should avoid excessive press, water, damp and sunshine.