



Product Specification

Part Name: 3.00 inch TFT Display Module

Customer Part ID:

Topovision Part ID: TVT0300D1-T

Ver: A

Customer:
Approved by

From: Topovision Technology Co., Ltd.
Approved by

Notes:

1. Please contact Topovision Technology Co., Ltd. before assigning your product based on this module specification
2. The information contained herein is presented merely to indicate the characteristics and performance of our products. No responsibility is assumed by Topovision Technology Co., Ltd. for any intellectual property claims or other problems that may result from application based on the module described herein.

Table of Contents

Table of Contents	2
Record of Revision	3
1 General Specifications	4
2 Input/Output Terminals	5
3 Absolute Maximum Ratings	7
4 Electrical Characteristics	8
5 Timing Chart.....	10
6 Optical Characteristics	15
7 Environmental / Reliability Test	20
8 Mechanical Drawing	22
9 Packing Drawing	23
10 Precautions for Use of LCD Modules	24
11 IIS	26

1 General Specifications

	Feature	Spec
Display Spec.	Size	3,0"
	Resolution	240(RGB)x400
	Technology Type	a-si TFT
	Pixel Configuration	RGB Vertical Stripe
	Pixel pitch(mm)	0.162x0.162
	Display Mode	ECB Mode, Transflective
	Surface Treatment	HC Type($\frac{1}{4} \lambda$ haze63%), clear
	Viewing Direction	5 o'clock
	Gray Scale Inversion Direction	11 o'clock
Mechanical Characteristics	LCM (W x H x D) (mm)	76.65x46.48x2.97
	Active Area(mm)	38.88x64.8
	With /Without TSP	Without TP
	Matching Connection Type	Molex 55909-0574
	LED Numbers	6LEDs
	Weight (g)	(21.2g)
Electrical Characteristics	Interface	CPU 16 bits
	Color Depth	65K
	Driver IC	HX8352-B00

Note 1: Viewing direction for best image quality is different from TFT definition. There is a 180 degree shift.

Note 2: Requirements on Environmental Protection: Q/S0002

Note 3: LCM weight tolerance: $\pm 5\%$

Note 4: Polarizer absorption angle as follow:

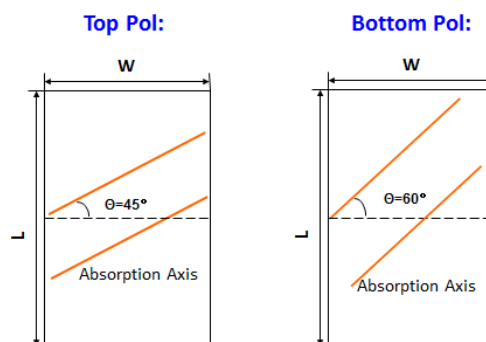

Top view from **Protective Film** side

2 Input/Output Terminals

Matched connector: Molex 55909-0574

Pin No.	Symbol	I/O	Function	Remark
1	ID2	O	Identification(pull VDD 1.8V internally)	
2	GND	P	Ground	
3	GND	P	Ground	
4	RESB	I	System reset	
5	NC	-	Not connect	
6	DB15	I	Data signal	
7	DB14	I	Data signal	
8	DB13	I	Data signal	
9	DB12	I	Data signal	
10	DB11	I	Data signal	
11	DB10	I	Data signal	
12	DB9	I	Data signal	
13	DB8	I	Data signal	
14	NC	-	Not connect	
15	DB7	I	Data signal	
16	DB6	I	Data signal	
17	DB5	I	Data signal	
18	DB4	I	Data signal	
19	DB3	I	Data signal	
20	DB2	I	Data signal	
21	DB1	I	Data signal	
22	DB0	I	Data signal	
23	NC	P	Not connect	
24	LED-K	-	Power supply for LED(Cathode)	
25	NC	P	Not connect	
26	LED-A1	-	Power supply for LED of full(Anode)	
27	GND	P	Ground(pull low internally)	
28	GND	P	Ground	
29	ID1	O	Identification(pull VDD 1.8V internally)	

30	TE	O	Tearing effect output	
31	GND	P	Ground	
32	GND	P	Ground	
33	GND	P	Ground	
34	GND	P	Ground	
35	GND	P	Ground	
36	GND	P	Ground	
37	NC	-	Not connect	
38	VDD	P	Voltage input pin for logic I/O	
39	VCI	P	Booster input voltage pin	
40	IM0	I	Interface mode select pin	
41	IM1	I	Interface mode select pin	
42	IM2	I	Interface mode select pin	
43	GND	P	Ground	
44	GND	P	Ground	
45	GND	P	Ground	
46	NC	-	Not connect	
47	RD	I	Read control input pin	
48	WR	I	Write control input pin	
49	RS	I	Resister select input pin	
50	CS	I	Chip select pin of serial interface	

Note1: Please add the FPC connector type and matched one if necessary .

3 Absolute Maximum Ratings

GND=0V

Item	Symbol	MIN	MAX	Unit	Remark
Power Voltage	VCC	-0.3	4.6	V	Note1
Input voltage	V _{IN}	-0.3	4.6	V	
Operating Temperature	Top	-20	70	°C	
Storage Temperature	Tst	-30	85	°C	
Relative Humidity Note2	RH	--	≤95	%	Ta≤40°C
		--	≤85	%	40°C < Ta ≤ 50°C
		--	≤55	%	50°C < Ta ≤ 60°C
		--	≤36	%	60°C < Ta ≤ 70°C
		--	≤24	%	70°C < Ta ≤ 80°C
Absolute Humidity	AH	--	≤70	g/m ³	Ta > 70°C

Table 3 Absolute Maximum Ratings

Note1: Input voltage include R0~R5, G0~G5, B0~B5, Dotclk, Hsync, Vsync, Enable, R/L, U/D.

Note2: Ta means the ambient temperature.

It is necessary to limit the relative humidity to the specified temperature range.

Condensation on the module is not allowed.

4 Electrical Characteristics

4.1 LCD Module

GND=0V, Ta=25°C

Item	Symbol	MIN	TYP	MAX	Unit	Remark
Logic Supply Voltage	IOVCC	1.65	1.8	3.3	V	
Analog Supply Voltage	VCC	2.5	3.0	3.3	V	
Input Signal Voltage	High Level	0.7 IOVCC	-	IOVCC	V	
	Low Level	-	-	0.3 IOVCC	V	
Output Signal Voltage	High Level	0.8 IOVCC	-	-	V	
	Low Level	-	-	0.2 IOVCC	V	

Table 4.1 LCD module electrical characteristics

4.2 Backlight Unit

Ta=25°C

Item	Symbol	MIN	TYP	MAX	Unit	Remark
Forward Current	I_F	-	20	-	mA	One LED
Forward Voltage	V_F	2.6	2.9	3.2	V	One LED
Backlight Power Consumption	W_{BL}	-	348	-	mW	6LEDs
Lifetime	T	-	20000	-	Hr	One LED
WLED part number	Nichia NSSW 306D					

Table 4.2.1 backlight unit electrical characteristics

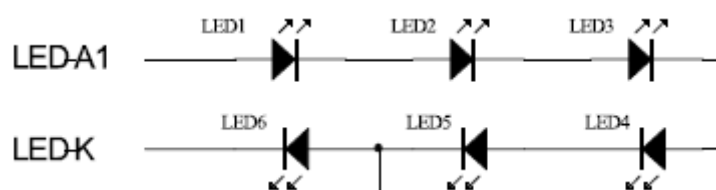

Figure 4.2.1 LED backlight circuit

4.3 Block Diagram

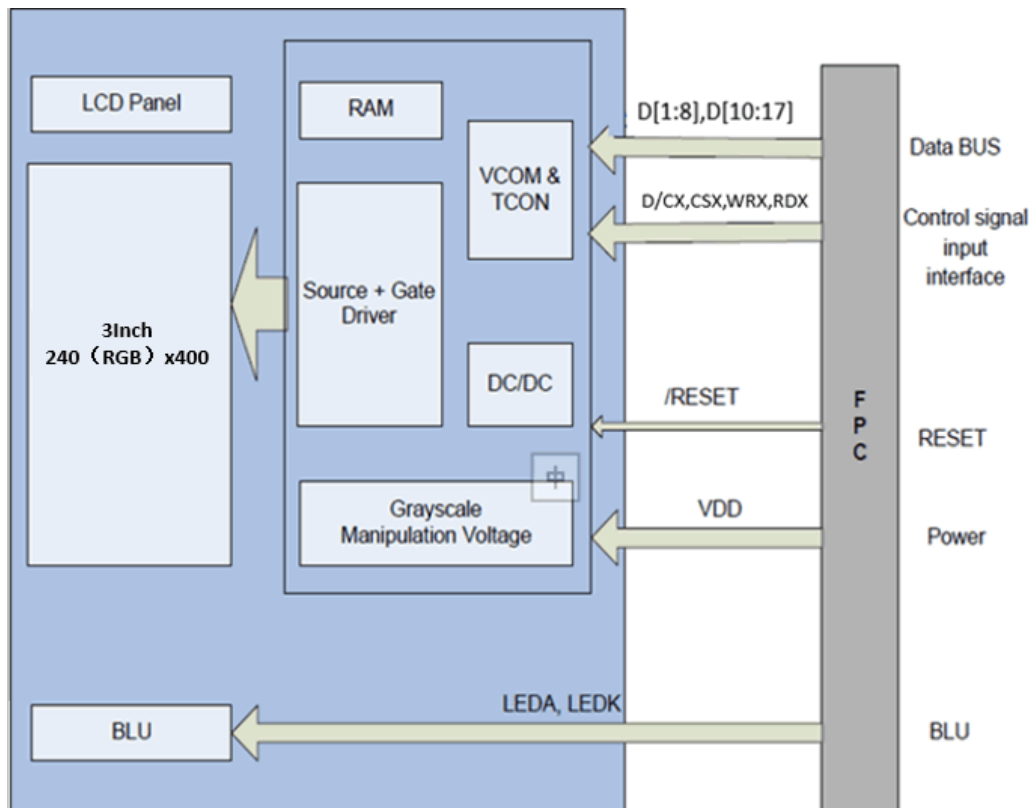
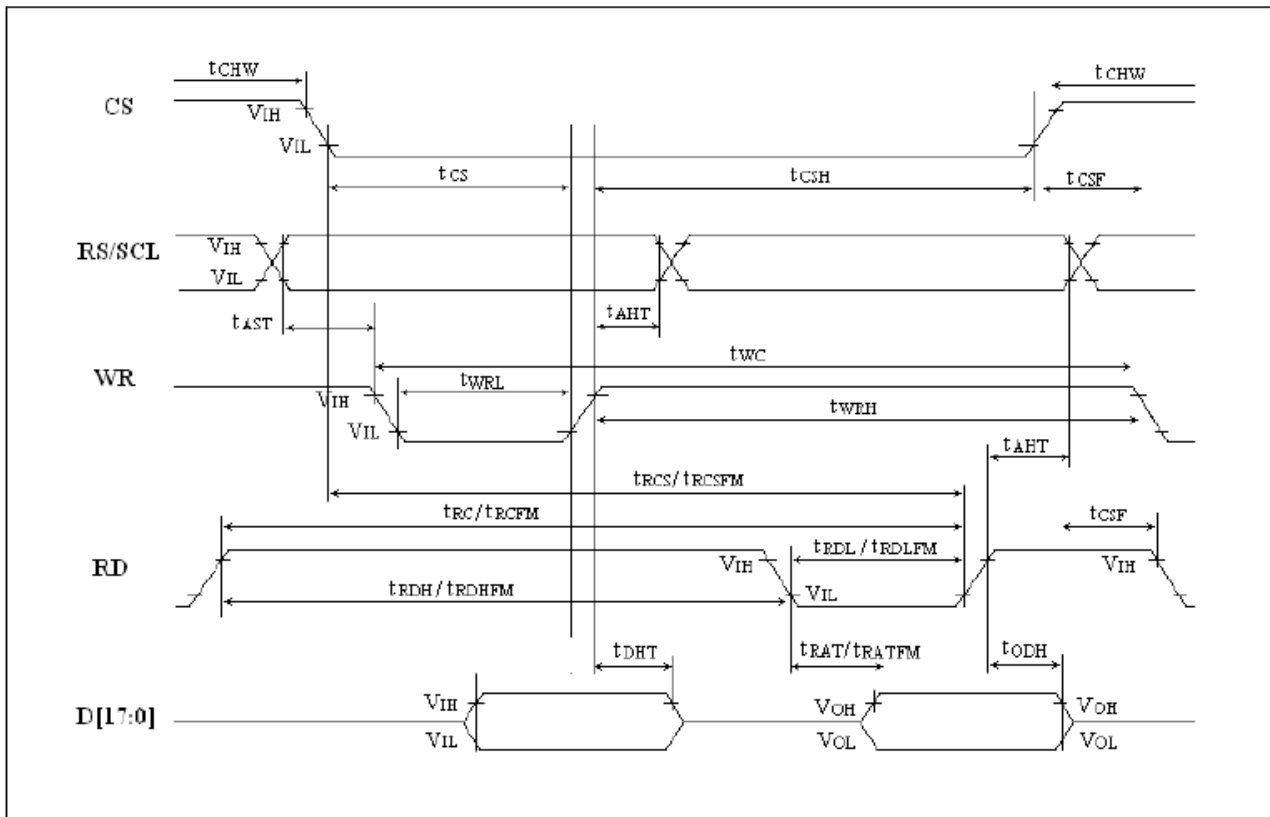

Figure 4.3 LCD module diagram

5 Timing Chart

5.1 AC Characteristics

5.1.1 CPU Interface Characteristics



CPU Interface Characteristics

Table 5.1 AC Characteristics

5.2 CPU Interface Input Timing parameters

Normal Write Mode (IOVCC=1.65~3.3V, VCC=2.3~3.3V)

Signal	Symbol	Parameter	Spec.			Description
			Min.	Max.	Unit	
RS/SCL	t_{AST}	Address setup time	10	-	ns	-
	t_{AHT}	Address hold time(Write/Read)	10	-		
CS	t_{CHW}	Chip select "H" pulse width	0	-	ns	-
	t_{CS}	Chip select setup time (Write)	35	-		
	t_{RCSFM}	Chip select setup time	355	-		
	t_{CSF}	Chip select wait time(Write/Read)	10	-		
	t_{CSH}	Chip select hold time	10	-		
WR	t_{WC}	Write cycle	100	-	ns	-
			33(5)	-		
	t_{WRH}	Control pulse "H" duration	15	-	ns	
RD	t_{WRL}	Control pulse "L" duration	15	-	ns	When read from GRAM
	t_{RC}	Read cycle	450	-		
	t_{RDH}	Control pulse "H" duration	90	-		
D[17:0]	t_{RDL}	Control pulse "L" duration	355	-	ns	For maximum $C_L=30pF$ For minimum $C_L=8pF$
	t_{DST}	Data setup time	15	-		
	t_{DHT}	Data hold time	10	-		
	t_{RATFM}	Read access time	-	340(4)		
	t_{ODH}	Output disable time	20(4)	80(4)		

CPU Interface Timing Parameters

Table 5.2 CPU Input Timing Parameters

5.3 CPU Interface Register write/read timing

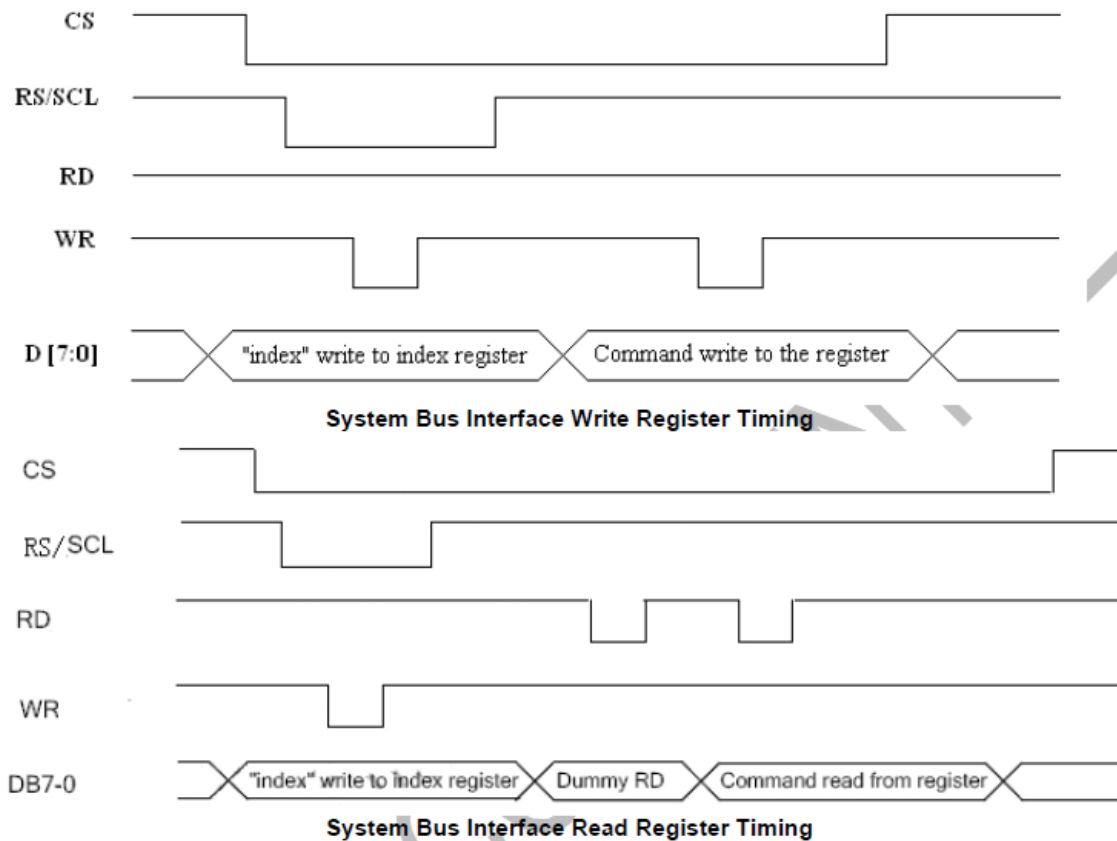
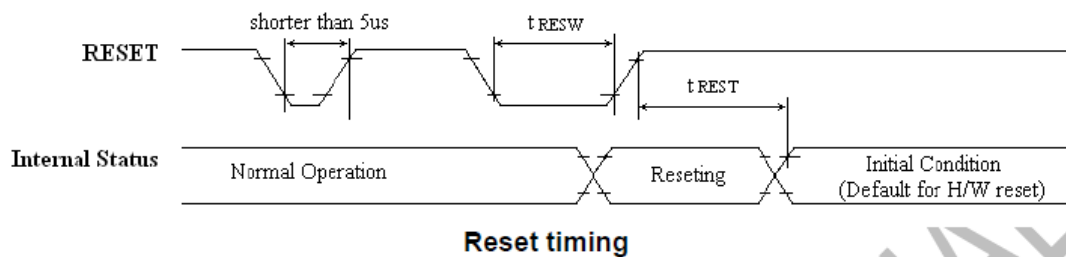

Figure 5.3 CPU Interface Register write/read timing

5.4 Reset timing



Reset input timing							
Symbol	Parameter	Related Pins	Spec.			Note	Unit
			Min.	Typ.	Max.		
t_{RESW}	Reset low pulse width	RESET	10	-	-	-	us
t_{REST}	Reset complete time	-	-	-	5	When reset applied during "Sleep In mode"	ms
		-	-	-	120	When reset applied during "Sleep Out mode"	ms

Figure 5.4.2 SYNC-DE Mode Timing Diagram

5.5 POWER ON/OFF SEQUENCE

5.5.1 POWER ON SEQUENCE

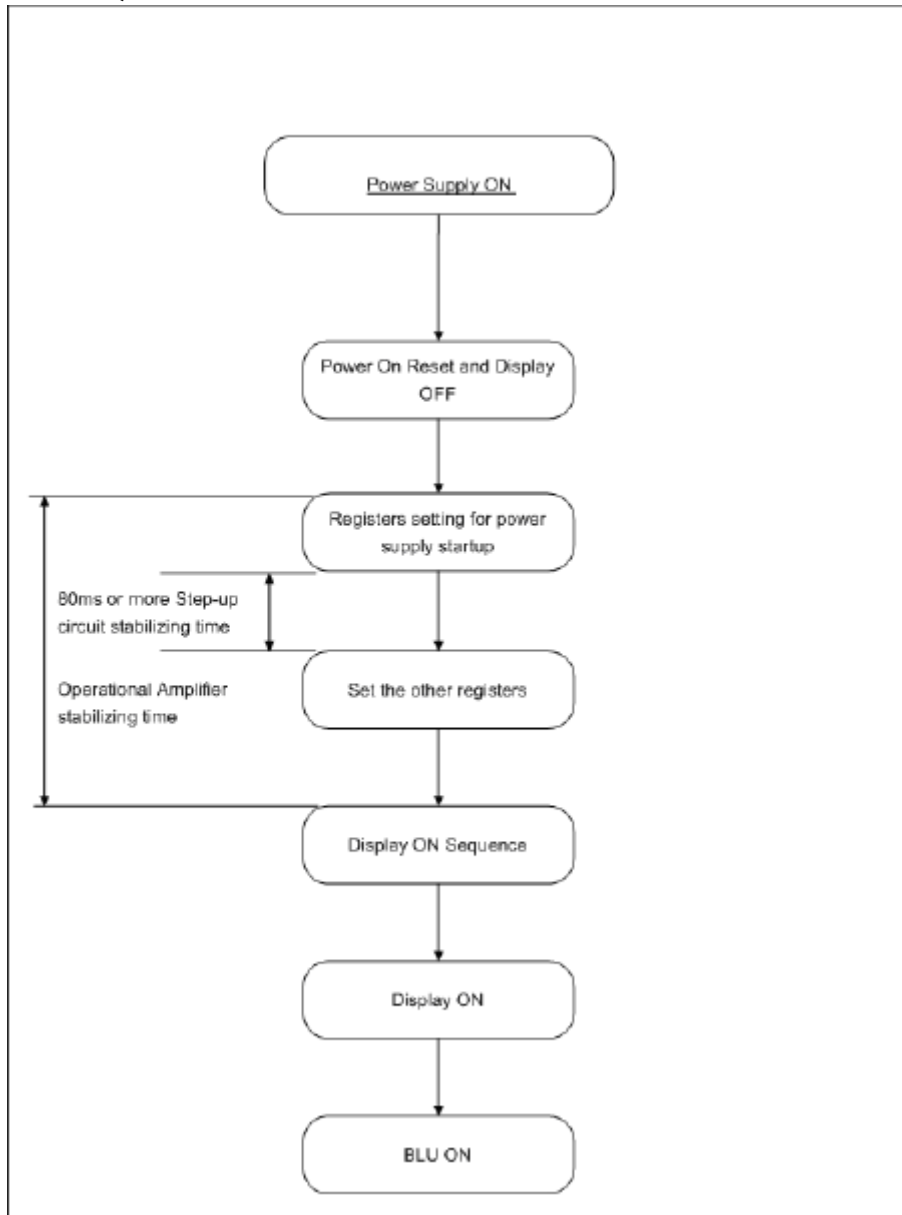

Figure 5.5.1 Power on Sequence

5.5.2 POWER OFF SEQUENCE

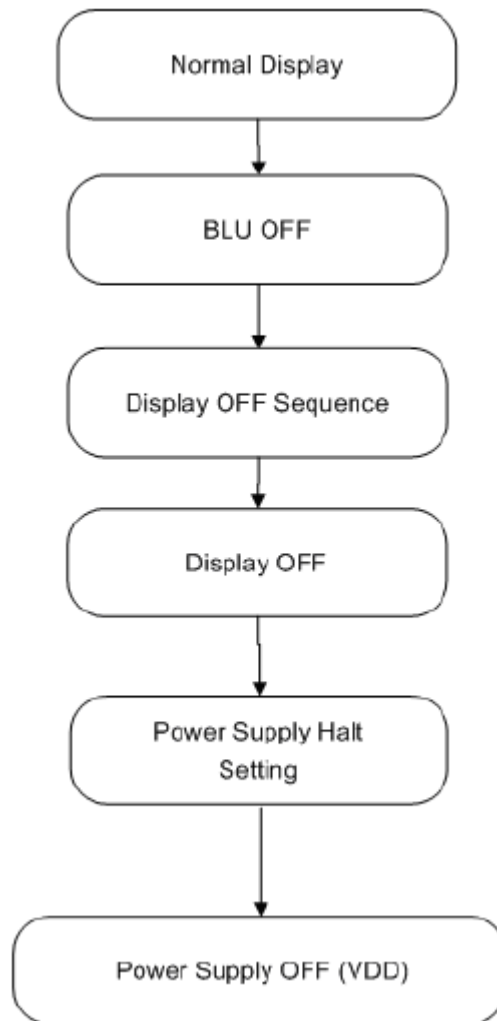

Figure 5.5.2 Power off Sequence

6 Optical Characteristics

6.1 Driving the backlight condition(Transmissive mode)

Item	Symbol	Condition	Min	Typ	Max	Unit	Remark
View Angles	θT	CR \geq 10	35	45	-	Degree	Note2,3
	θB		30	40	-		
	θL		35	45	-		
	θR		30	40	-		
Contrast Ratio	CR	$\theta=0^\circ$	60	80	120		Note 3
Response Time	T _{ON}	25°C	20	30	50	ms	Note 4
	T _{OFF}						
Chromaticity	White	Backlight is on	x	0.280	0.310	0.340	Note 1,5
			y	0.301	0.331	0.361	
	Red		x	0.473	0.503	0.533	Note 1,5
			y	0.315	0.345	0.375	
	Green		x	0.280	0.310	0.340	Note 1,5
			y	0.501	0.531	0.561	
	Blue		x	0.132	0.162	0.192	Note 1,5
			y	0.107	0.137	0.167	
Uniformity	U		-	80%		%	Note 6
NTSC			28	33	38	%	Note 5
Luminance	L		130	150		cd/m ²	Note 7
Flicker					-25	dB	
Crosstalk					3%		

Test Conditions:

1. I_F= 20mA, and the ambient temperature is 25°C.
2. The test systems refer to Note 1 and Note 2.

6.2 Not Driving the backlight condition(Reflective mode)

Item	Symbol	Condition	Min	Typ	Max	Unit	Remark
View Angles	θT	CR \geq 5	25	35	-	Degree	Note2,3
	θB		25	35	-		
	θL		20	30	-		
	θR		20	30	-		
Contrast Ratio	CR	$\theta=0^\circ$	8	10	-		Note 3
Response Time	T _{ON}	25°C	10	20	40	ms	Note 4
	T _{OFF}						
Chromaticity	White	Backlight is off	x	0.301	0.331	0.361	Note 1,5
			y	0.33	0.360	0.39	
	Red		x	0.388	0.418	0.448	Note 1,5
			y	0.327	0.357	0.387	
	Green		x	0.3	0.330	0.36	Note 1,5
			y	0.388	0.418	0.448	
	Blue		x	0.18	0.210	0.24	Note 1,5
			y	0.213	0.243	0.273	
Reflection ratio	U		6.55	7.27	7.63	%	
NTSC			6.2	7.35	8.5	%	
Flicker					-30	dB	

Test Conditions:

1. I_F= 20 mA, and the ambient temperature is 25°C.
2. The test systems refer to Note 1 and Note 2.
3. Flicker pattern(pixel inversion: Line inversion)



**Flicker for line
inversion**

Note 1: Definition of optical measurement system.

1. Transmissive mode: The optical characteristics should be measured in dark room. After 5 Minutes operation, the optical properties are measured at the center point of the LCD screen. All input terminals LCD panel must be ground when measuring the center area of the panel.

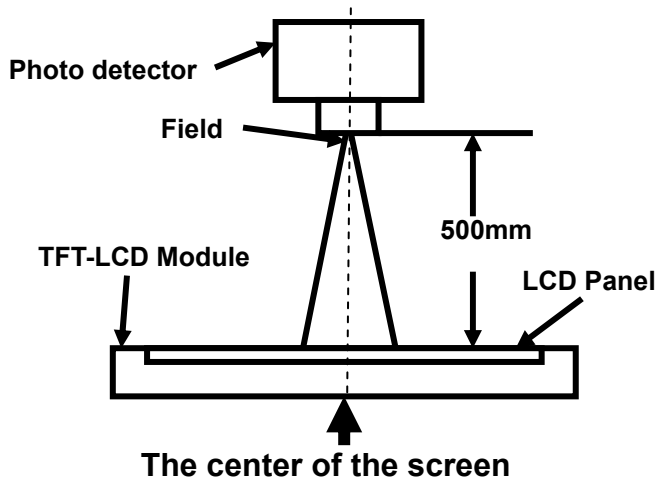

Item	Photo detector	Field
Contrast Ratio	SR-3A	1°
Luminance		
Chromaticity		
Lum Uniformity		
Response Time	LCD-5200	/
Flicker	CA-310	/

2. Reflective mode

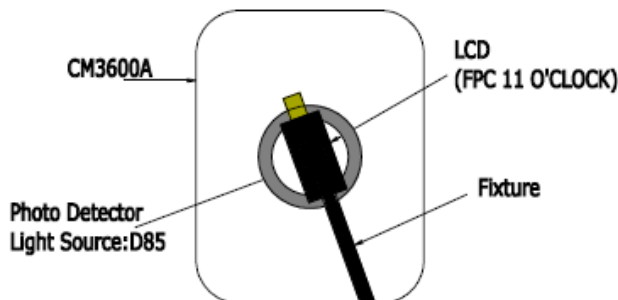

Item	Photo detector	Field
Chromaticity	CM-3600A	
Reflective Ratio		
Contrast Ratio		
Viewing angle	LCD-5200	
Flicker		

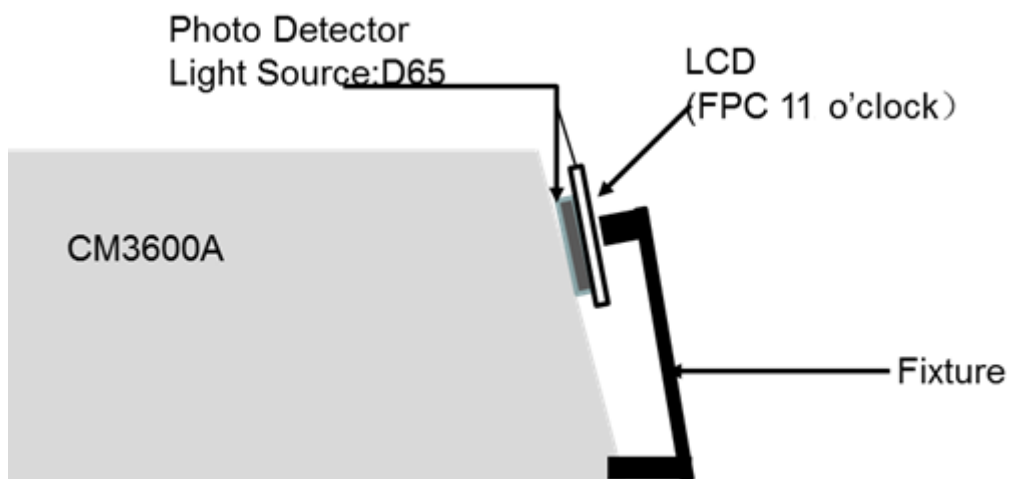

Note 2: Definition of viewing angle range and measurement system.

viewing angle is measured at the center point of the LCD by CONOSCOPE(ergo-80).

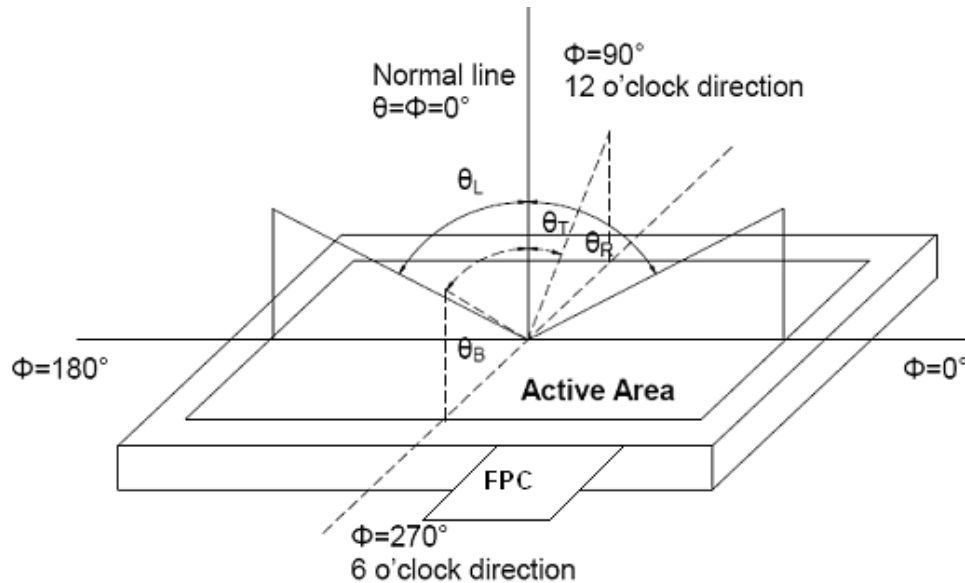

Note 3: Definition of contrast ratio

$$\text{Contrast ratio (CR)} = \frac{\text{Luminance measured when LCD is on the "White" state}}{\text{Luminance measured when LCD is on the "Black" state}}$$

“White state “: The state is that the LCD should drive by V_{white} .

“Black state”: The state is that the LCD should drive by V_{black} .

V_{white} : To be determined V_{black} : To be determined.

Note 4: Definition of Response time

The response time is defined as the LCD optical switching time interval between “White” state and “Black” state. Rise time (T_{ON}) is the time between photo detector output intensity changed from 90% to 10%. And fall time (T_{OFF}) is the time between photo detector output intensity changed from 10% to 90%.

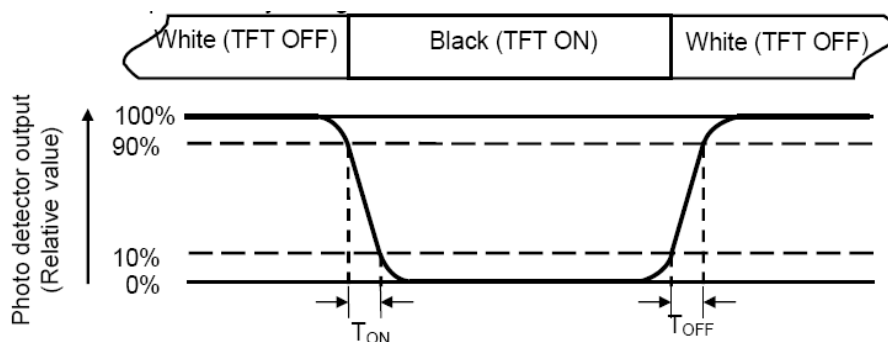

Note 5: Definition of color chromaticity (CIE1931)

- (1) Color coordinates measured at center point of LCD.
- (2) For reflective mode color chromaticity we need to test at least 3 different batches to make sure the stability of panel and it accepts reasonable change after we get the stability data.

Note 6: Definition of Luminance Uniformity

Active area is divided into 9 measuring areas (Refer Fig. 2). Every measuring point is placed at the center of each measuring area.

$$\text{Luminance Uniformity (U)} = L_{\min} / L_{\max}$$

L-----Active area length W----- Active area width

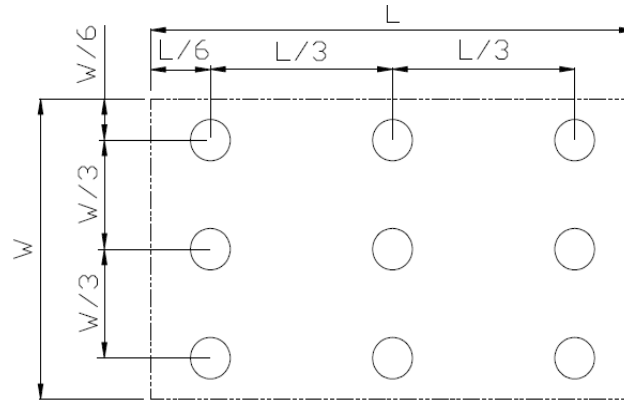

L_{\max} : The measured Maximum luminance of all measurement position.

L_{\min} : The measured Minimum luminance of all measurement position.

Note 7: Definition of Luminance:

Measure the luminance of white state at center point.

7 Environmental / Reliability Test

No	Test Item	Condition	Remarks
1	High Temperature Operation	Ta=+70°C, 240hrs	IEC60068-2-1:2007 GB2423.2-2008
2	Low Temperature Operation	Ta=-20°C, 240hrs	IEC60068-2-1:2007 GB2423.1-2008
3	High Temperature Storage	Ta=+85°C, 240hrs	IEC60068-2-1:2007 GB2423.2-2008
4	Low Temperature Storage	Ta=-30°C, 240hrs	IEC60068-2-1:2007 GB2423.1-2008
5	Storage at High Temperature and Humidity	Ta=+60°C, 90% RH 240 hours	IEC60068-2-78 :2001 GB/T2423.3—2006
6	Thermal Shock (non-operation)	-40°C 60 min~+85°C 60 min, Change time:5min, 50 Cycles	Start with cold temperature, End with high temperature, IEC60068-2-14:1984,G B2423.22-2002
7	ESD	C=150pF, R=330Ω , 5points/panel Air:±6KV, 5times; Contact:±4KV, 5 times; (Environment: 15°C~35°C, 30%~60%, 86Kpa~106Kpa)	IEC61000-4-2:2001 GB/T17626.2-2006
8	Vibration Test	Frequency range:10~55Hz, Stroke:1.5mm Sweep:10Hz~55Hz~10Hz 2 hours for each direction of X.Y.Z. (for total)(Package condition)	IEC60068-2-6:1982 GB/T2423.10—1995
9	Mechanical Shock (Non OP)	60G 6ms, ±X,±Y,±Z 3times, for each direction	IEC60068-2-27:1987 GB/T2423.5—1995
10	Package Drop Test	Drop onto the field floor from 76 cm heights, 6 faces, 3 edges and one of 8 corners. Total is 10 times	IEC60068-2-32:1990 GB/T2423.8—1995
11	Image sticking test	40° 6 hours judge without release	No Image sticking

Note1: Ta is the ambient temperature of sample.

Note2: Before cosmetic and function test, the product must have enough recovery time, at least 2 hours at room temperature.

Note 3: In the standard condition, there shall be no practical problem that may affect the display function. After the reliability test, the product only guarantees operation, but don't guarantee all of the cosmetic specification.

Note 4: Image sticking test is as below.

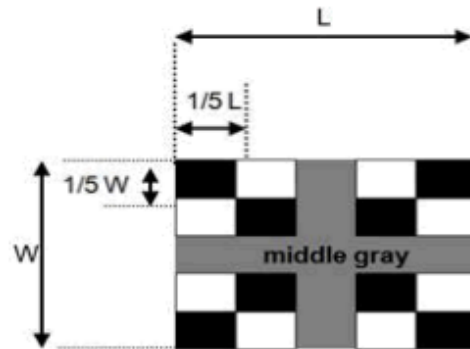

9 Packing Drawing

9.1 Packaging flow

No	Item	Model (Material)	Dimensions(m m)	Unit Weight(Kg)	Quantity	Remark	
1	LCM modle	TVT0300D1-T	76.65*46.48*2.97	(0.0212)	336		
2	Carton	Corrugated paper	544*365*250	1.01	1		
3	Dust-Proof Bag	PE	700*545*0.05	0.046	1		
4	EPE	EPE	485*330x5	0.08	3		
5	Tray	PET(Transmit)	485*330*13.8	0.156	24		
6	BOX	Corrugated paper	520*345*74	0.44	3		
7	Total weight	(13.48)±10%					

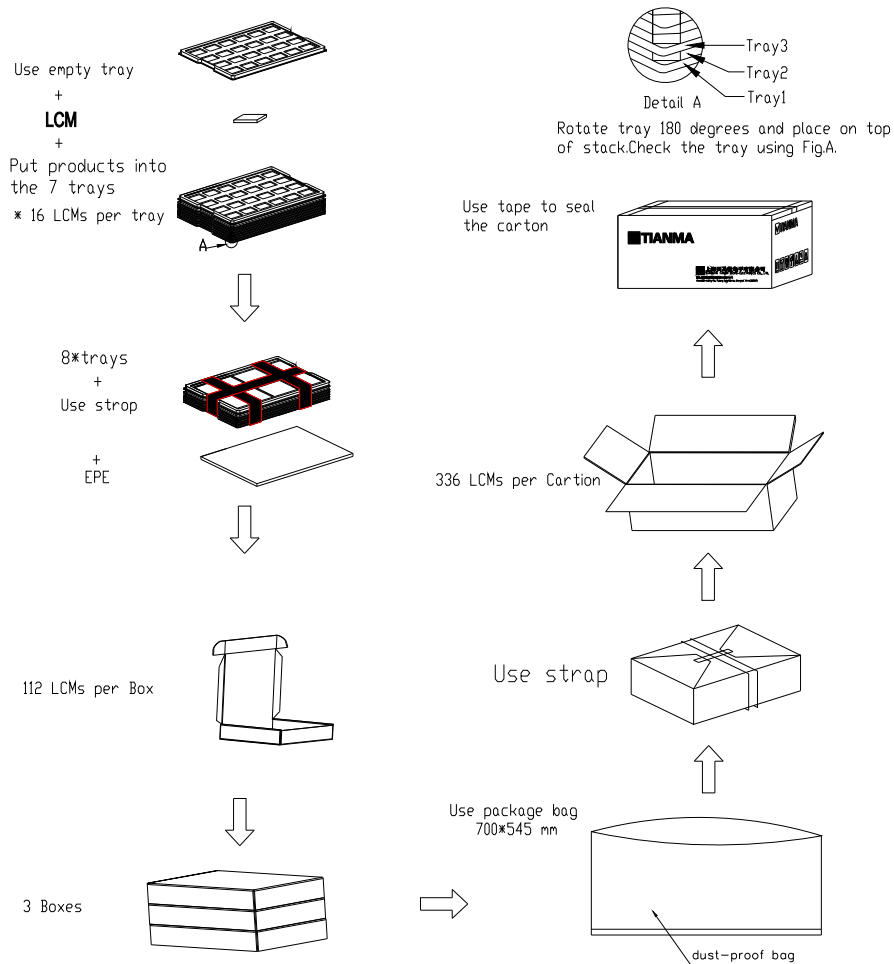

10 Precautions for Use of LCD Modules

10.1 Handling Precautions

10.1.1 The display panel is made of glass. Do not subject it to a mechanical shock by dropping it from a high place, etc.

10.1.2 If the display panel is damaged and the liquid crystal substance inside it leaks out, be sure not to get any in your mouth, if the substance comes into contact with your skin or clothes, promptly wash it off using soap and water.

10.1.3 Do not apply excessive force to the display surface or the adjoining areas since this may cause the color tone to vary.

10.1.4 The polarizer covering the display surface of the LCD module is soft and easily scratched. Handle this polarizer carefully.

10.1.5 If the display surface is contaminated, breathe on the surface and gently wipe it with a soft dry cloth. If still not completely clear, moisten cloth with one of the following solvents:

- Isopropyl alcohol
- Ethyl alcohol

Solvents other than those mentioned above may damage the polarizer. Especially, do not use the following:

- Water
- Ketone
- Aromatic solvents

10.1.6 Do not attempt to disassemble the LCD Module.

10.1.7 If the logic circuit power is off, do not apply the input signals.

10.1.8 To prevent destruction of the elements by static electricity, be careful to maintain an optimum work environment.

10.1.8.1 Be sure to ground the body when handling the LCD Modules.

10.1.8.2 Tools required for assembly, such as soldering irons, must be properly ground.

10.1.8.3 To reduce the amount of static electricity generated, do not conduct assembly and other work under dry conditions.

10.1.8.4 The LCD Module is coated with a film to protect the display surface. Be care when peeling off this protective film since static electricity may be generated.

10.2 Storage precautions

10.2.1 When storing the LCD modules, avoid exposure to direct sunlight or to the light of fluorescent lamps.

10.2.2 The LCD modules should be stored under the storage temperature range. If the LCD modules will be stored for a long time, the recommend condition is:

Temperature : 0°C ~ 40°C Relatively humidity: ≤80%

10.2.3 The LCD modules should be stored in the room without acid, alkali and harmful gas.

10.3 Transportation Precautions

10.3.1 The LCD modules should be no falling and violent shocking during transportation, and also should avoid excessive press, water, damp and sunshine.

10.4 Bar Code definition on module

Note: Bar Code definition

Definition of first line of label is Panel ID, and it is unique and includes manufacture relevant information, for instance **TVT0300D1-T**

From the 11 number to the 33 number of Label definition as below

01HD03XPA12MG11504006

01 meaning is **01** edition

H meaning is **2015** year. (A meaning is 2008, B meaning is 2009,)

D meaning is April(A meaning is January, B meaning is February,)

03 meaning is **date 03**.

XPA12MG11504006 meaning is producing number

HongKong TopovisionTechnology CO.,LTD

TFT-LCD Module Incoming Inspection Standard

Customer	
Description	TFT-LCM
Model Name	3.0
Date	2016.5.31
Version	1.1

Customer Approval	
Title	
Name	
Date	

	Prepared By	Checked by	Approved By
Title:			
Name:			
Date:			

HISTORY OF REVISION

REV NO.	REV DATE	CONTENTS	REMARKS
1.0	2016-5-27		

1. Scope:

The incoming inspection standards shall be applied to TFT-LCD Modules (hereinafter called "Modules") that supplied by Topovision.

2. Incoming Inspection

The customer shall inspect the modules within twenty calendar days of the delivery date (the "inspection period") at its own cost. The result of the inspection (acceptance or rejection) shall be recorded in writing, and a copy of this writing will be promptly sent to the seller, If the results of the inspecting from buyer does not send to the seller within twenty calendar days of the delivery date. The modules shall be regards as acceptance.

Should the customer fail to notify the seller within the inspection period, the buyers right to reject the modules. Shall be lapsed and the modules shall be deemed to have been accepted by the buyer.

3. Inspection Sampling Method

3.1. Lot size: Quantity per shipment lot per model

3.2. Sampling type: Normal inspection, Single sampling

3.3. Inspection level: II

3.4. Sampling table: MIL-STD-1916

3.5. Acceptable quality level (AQL)

Major defect: accept:0, reject:1

Minor defect: AQL=1.00

4. Inspection Conditions

4.1 Ambient conditions:

a. Temperature: Room temperature $25\pm 5^{\circ}\text{C}$

b. Humidity: $(60\pm 10)\% \text{RH}$

c. Illumination: Appearance 700 ± 100 Lux, Display 100 ± 50 Lux (The luminance at an inspection desk surface with single non-directive fluorescent lamp)

4.2 Viewing distance

The distance between the LCD and the inspector's eyes shall be at least 30 ± 5 cm.

4.3 Viewing Angle

U/D: $45^{\circ}/45^{\circ}$ L/R: $45^{\circ}/45^{\circ}$

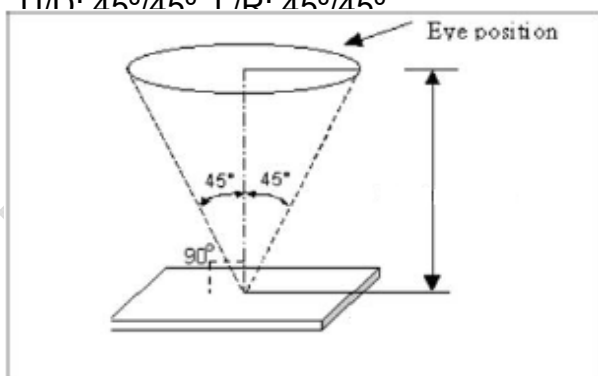

5. Inspection Criteria

Defects are classified as major defects and minor defects according to the degree of defectiveness defined herein.

5.1 Major defect

Item No	Items to be inspected	Inspection Standard
5.1.1	All functional defects	1) No display 2) Display abnormally 3) Short circuit 4) line defect
5.1.2	missing	Missing function component
5.1.3	Crack	Glass Crack

5.2 Minor defect

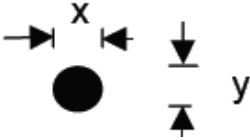
Item No	Items to be inspected	Inspection standard	
5.2.1	Spot Defect Including Black spot White spot Pinhole Foreign particle Polarizer dirt	For dark/white spot is defined $\varphi = (x+y) / 2$	
			
		Size φ (mm)	Acceptable Quantity
		$\varphi \leq 0.1$	Ignore
		$0.1 < \varphi \leq 0.2$	2 two defects distance must over 3mm
		$0.2 < \varphi$	Not allowed
5.2.2	Line Defect	Define:	

	Including Black line White line Scratch		
		Width(mm) Length(mm)	Acceptable Quantity
		$W \leq 0.02$	Ignore
		$0.02 < W \leq 0.05$ $L \leq 2.0$	1 <u>Two defects distance must over 3mm</u>
		$0.05 < W$	Follow 5.2.1
5.2.3	Polarizer Dent/Bubble	Size ϕ (mm)	Acceptable Quantity
		$\phi \leq 0.1$	Ignore
		$0.1 < \phi \leq 0.2$	2 two defects distance must over 3mm
		$0.2 < \phi$	Not allowed
5.2.4	Electrical Dot Defect	Bright and Black dot define:	
		Item	Acceptable Quantity
		Dark dot defect	2
		Bright dot defect	0
Total Dot	2		
5.2.5	Pol 異物 Cell 異物 (发亮)	Size ϕ (mm)	Acceptable Quantity
		$\phi \leq 0.1$	Ignore
		$0.1 < \phi \leq 0.2$	2

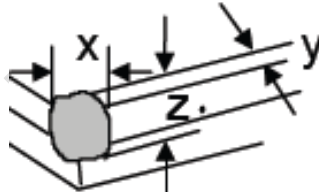
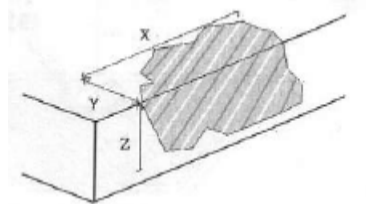
			two defects distance must over 3mm
		$0.2 < \phi$	Not allowed
5.2.6	密集微小亮点	微小亮点判定方法: $\Phi < 0.1\text{mm}$	
		Not accepted under 2% ND filter	
5.2.7	Mura	Not accepted under 6% ND filter, but a limits sample will be allowed	
5.2.8	FPC	Broken	Not allowed
		FPC 折痕、压痕、顶伤	不可裸线、漏洞 弯曲不可形成锐角
5.2.9	Glass defect & Touch panel defect	1. Corner Fragment: 	
		Size(mm)	Acceptable Quantity
		$X \leq 3\text{mm}$ $Y \leq 3\text{mm}$ $Z \leq T$	Ignore T : Glass thickness X: Length Y: Width Z: thickness
		2. Side Fragment: 	
		Size(mm)	Acceptable Quantity

		$X \leq 5.0\text{mm}$ $Y \leq 1.0\text{mm}$ $Z \leq T$	Ignore T : Glass thickness X: Length Y: Width Z: thickness
5.2.10	Touch panel spot	Size ϕ (mm)	Acceptable Quantity
		$\phi \leq 0.20$	Ignore
		$0.20 < \phi \leq 0.30$	3
		$0.30 < \phi$	Not allowed
5.2.11	Touch panel newton ring	Compare with limit sample	
5.2.12	Bezel	Dirt	No harm
		Wrap	
		Broken	
		凹陷	No dangerous
5.2.13	检验画面	<u>red · green · blue · black · white · color scale · PIC · Image sticking · Cross-talk · flicker</u>	

- Note:
1. Dot defect is defined as the defective area of the dot area is larger than 50% of the dot area.
 2. Polarizer bubble is defined as the bubble appears on active display area. The defect of polarizer bubble shall be ignored if the polarizer bubble appears on the outside of active display area.
 3. ND 使用方法：ND 与 panel 平行垂直距离 3~5cm，肉眼与 panel 正视距离 $30 \pm 5\text{cm}$
 4. Foreign particle on the surface of the LCM should be ignored.

6. Mechanics specification

As for the outside dimension, weight of the modules, please refer to product specification for more details

7. Precaution

Please pay attention to the following items when you use the LCD Modules:

- 7-1 Do not twist or bend the module and prevent the unsuitable external force for

- display module during assembly.
- 7-2 Adopt measures for good heat radiation. Be sure to use the module with in the specified temperature.
 - 7-3 Avoid dust or oil mist during assembly.
 - 7-4 Following the correct power sequence while operating. Do not apply the invalid signal, otherwise, it will cause improper shut down and damage the module.
 - 7-5 Less EMI: it will be more safety and less noise.
 - 7-6 Please operate module in suitable temperature. The response time & brightness will drift by different temperature.
 - 7-7 Avoid to display the fixed pattern (exclude the white pattern) in a long period, otherwise, it will cause image stains.
 - 7-8 Be sure to turn off the power when connection of disconnecting the circuit.
 - 7-9 Polarizer scratches easily, please handle it carefully.
 - 7-10 Display surface never likes dirt of stains.
 - 7-11 A dew drop may lead to destruction. Please wipe off and moisture before using module.
 - 7-12 Sudden temperature changes cause condensation, and it will cause polarizer damaged.
 - 7-13 High temperature and humidity may degrade performance. Please do not expose the module to the direct sunlight and so on.
 - 7-14 Acetic acid or chlorine compounds are not friends with TFT display module.
 - 7-15 Static electricity will damage the module, please do not touch the module without any grounded device.
 - 7-16 Do not disassemble and reassemble the module by self.
 - 7-17 Be careful do not touch the rear side directly.
 - 7-18 Not strong vibration or shock. It will cause module broken.
 - 7-19 Storage the modules in suitable environment with regular packing.
 - 7-20 Be careful or injury from a broken display module.
 - 7-21 Please avoid the pressure adding to the surface (front or rear side) of modules, because it will cause the display non-uniformity of other function issue.
 - 7-22 Please follow the storage environment conditions:
 - a. Temperature: Room temperature $23\pm 4^{\circ}\text{C}$
 - b. Humidity: $(50\pm 30)\% \text{RH}$.
 - 7-23 Display warranty period is one year.