



Product Specification

Part Name: 5.0 inch TFT Display Module

Customer Part ID:

Topovision Part ID: TVT0500P1-FT

Ver: A

Customer:
Approved by

From: Topovision Technology Co., Ltd.
Approved by

Sales@topo-vision.com

Notes:

1. Please contact Topovision Technology Co., Ltd. before assigning your product based on this module specification
 2. The information contained herein is presented merely to indicate the characteristics and performance of our products. No responsibility is assumed by Topovision Technology Co., Ltd. for any intellectual property claims or other problems that may result from application based on the module described herein.
-

Table of Contents

Table of Contents	2
Record of Revision.....	3
1 General Specifications.....	4
2 Input/Output Terminals	5
3 Absolute Maximum Ratings.....	7
4 Electrical Characteristics	8
5 Timing Chart.....	10
6 Optical Characteristics(with CTP).....	13
7 Environmental / Reliability Test.....	1919
8 Mechanical Drawing	200
9 Packing Drawing	211
10 Precautions for Use of LCD Modules.....	22

1 General Specifications

	Feature	Spec
Display Spec.	Size	5.0"
	Resolution	480(RGB)x800
	Technology Type	a-si TFT
	Pixel Configuration	RGB Vertical Stripe
	Pixel pitch(mm)	0.135X0.135
	Display Mode	ECB, full reflective
	Surface Treatment	HC
	Viewing Direction(IC at 6 o'clock)	5o'clock
	Gray Scale Inversion Direction	11o'clock
Mechanical Characteristics	LCM (W x H x D) (mm)	70.80X118.75X3.07
	Active Area(mm)	64.8x108.00
	Matching Connection Type	JAE FB10S051JT1
	LED Numbers	10LEDs
	Weight (g)	TBD
Electrical Characteristics	Interface	MCU 16bit
	Color Depth	65K
	Driver IC	ILI9806

Note 1: Viewing direction for best image quality is different from TFT definition. There is a 180 degree shift.

Note 2: Requirements on Environmental Protection: Q/S0002

Note 3: LCM weight tolerance: $\pm 5\%$

Note 4 : Top polarizer absorption angle as follow:

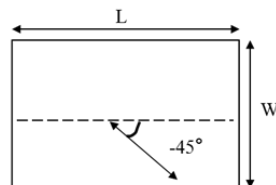

2 Input/Output Terminals

Matched connector: JAE FB10S051JT1

Pin No.	Symbol	I/O	Function	Remark
1	LEDA	P	Power supply for LED(Anode)	
2	LEDA	P	Power supply for LED (Anode)	
3	NC	-	No connection	
4	NC	-	No connection	
5	NC	-	No connection	
6	LEDK1	P	Power supply for LED(Cathode)	
7	LEDK2	P	Power supply for LED(Cathode)	
8	NC	-	No connection	
9	GND	P	Ground	
10	ID1	O	ID pin	Connect GNG
11	ID2	O	ID pin	Connect GNG
12	LEDPWM	O	The PWM Frequency output for LED driver control .	
13	GND	P	Ground	
14	GND	P	Ground	
15	DB0	I	Data signal	
16	DB1	I	Data signal	
17	DB2	I	Data signal	
18	DB3	I	Data signal	
19	DB4	I	Data signal	
20	DB5	I	Data signal	
21	DB6	I	Data signal	
22	DB7	I	Data signal	
23	DB8	I	Data signal	
24	DB9	I	Data signal	
25	DB10	I	Data signal	
26	DB11	I	Data signal	
27	DB12	I	Data signal	
28	DB13	I	Data signal	

29	DB14	I	Data signal	
30	DB15	I	Data signal	
31	GND	P	Ground	
32	GND	P	Ground	
33	RESET	I	Reset input pin	
34	VDD	P	Supply voltage	2.8V
35	VDD	P	Supply voltage	2.8V
36	NC	-	No connection	
37	GND	P	Ground	
38	IOVCC	P	Supply voltage(I/O)	1.8V
39	CS	I	A chip select signal	
40	DC	I	The signal for command	
41	RD	I	Serves as a read signal and read data at the rising edge	
42	WR	I	Serves as a write signal and writes data at the rising edge	
43	TE	O	Tearing effect signal pin	
44	GND	P	Ground	
45	GND	P	Ground	
46	TP_VCC	P	Supply voltage for CTP	
47	TP_INT	O	External interrupt from the host	<i>The host should be pull high through 100KΩ</i>
48	TP_SDA	I/O	I2C data input and output	
49	TP_SCL	I	I2C clock input	
50	TP_RST	I	Reset pin for CTP	
51	GND	P	Ground	

Note1: Please add the FPC connector type and matched one if necessary .

3 Absolute Maximum Ratings

GND=0V

Item	Symbol	MIN	MAX	Unit	Remark
Panel Analog Voltage	VDD	-0.3	4.6	V	Note1
Panel Input Voltage(I/O)	IOVCC	-0.3	4.6	V	
Operating Temperature	Top	-20	70	°C	
Storage Temperature	Tst	-40	85	°C	
Relative Humidity Note2	RH	--	≤95	%	Ta≤40°C
		--	≤85	%	40°C < Ta ≤ 50°C
		--	≤55	%	50°C < Ta ≤ 60°C
		--	≤36	%	60°C < Ta ≤ 70°C
		--	≤24	%	70°C < Ta ≤ 80°C
Absolute Humidity	AH	--	≤70	g/m ³	Ta > 70°C

Table 3 Absolute Maximum Ratings

Note1: Panel Input voltage include DB0~DB15,CS,DC,RD,WR,RESET

Note2: Ta means the ambient temperature.

It is necessary to limit the relative humidity to the specified temperature range.
Condensation on the module is not allowed.

Not3:

4 Electrical Characteristics

4.1 LCD Module

GND=0V, Ta=25°C

Item	Symbol	MIN	TYP	MAX	Unit	Remark
Logic Supply Voltage	IOVCC	1.7	1.8	1.9	V	
Analog Supply Voltage	VDD	2.7	2.8	2.9	V	
Input Signal Voltage	High Level	0.7 IOVCC	-	IOVCC	V	
	Low Level	-	-	0.3 IOVCC	V	
Output Signal Voltage	High Level	0.8 IOVCC	-	-	V	
	Low Level	-	-	0.2 IOVCC	V	
Power Consumption	Normal Mode	-	175	265	mW	
	Sleep mode	-	0.2	0.5	mW	

Table 4.1 LCD module electrical characteristics

4.2 Backlight Unit(ME)

Ta=25°C

Item	Symbol	MIN	TYP	MAX	Unit	Remark
Forward Current	I_F	-	20	-	mA	One LED
Forward Voltage	V_F	-	5.65	-	V	One LED
Backlight Power Consumption	W_{BL}	-	1130	-	mW	10LEDs
Lifetime	T	-	15000	-	Hr	One LED
WLED part number	NS2W266GT					

Table 4.2.1 backlight unit electrical characteristics

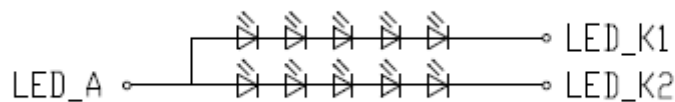

Figure 4.2.1 LED backlight circuit

4.3.1 Block Diagram

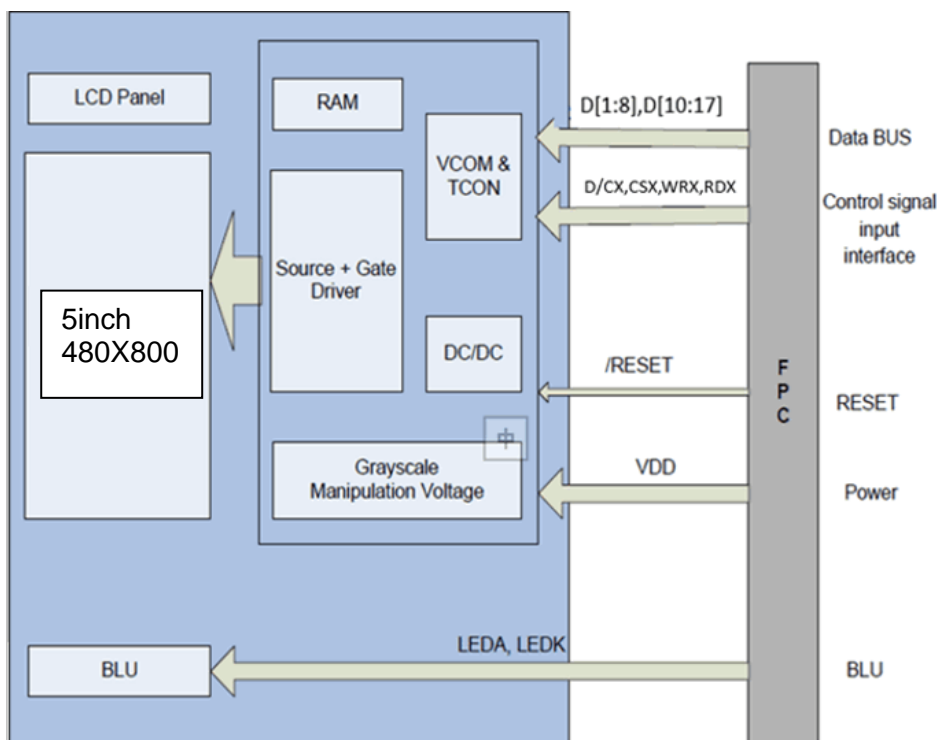

Figure 4.3 LCD module diagram

5 Timing Chart

5.1 AC Characteristics

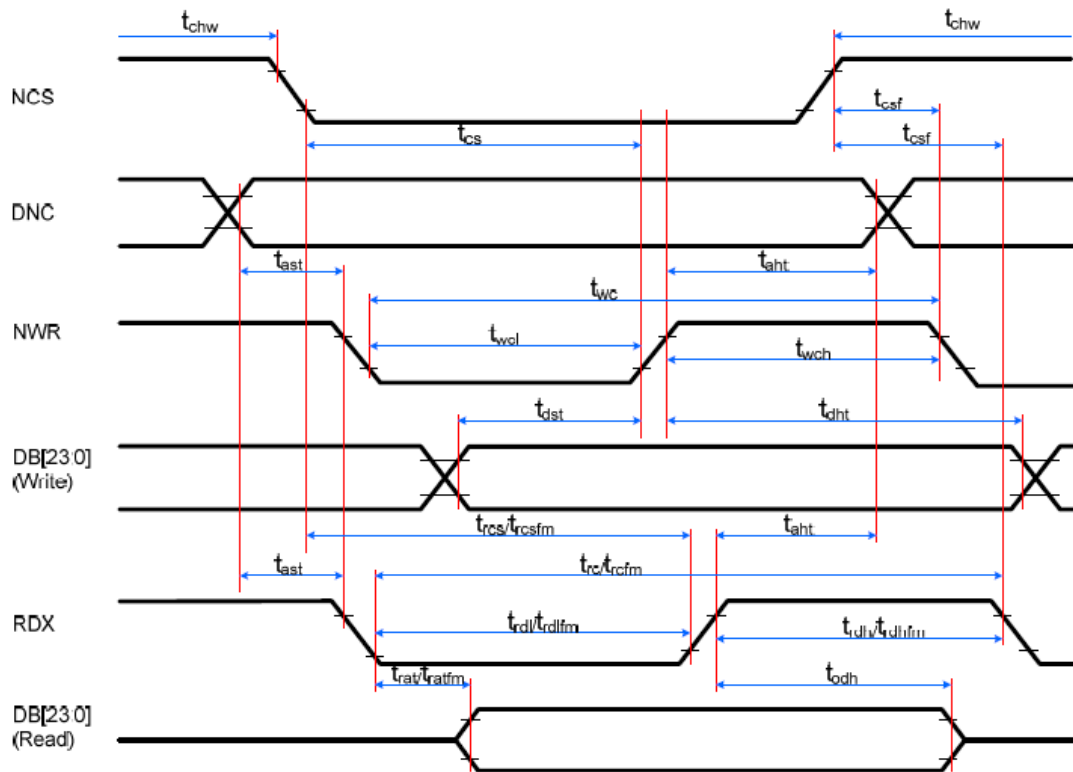

Table 5.1 MCU 8080 Interface AC Characteristics

5.2 MCU 8080 Interface Input Timing parameters

Signal	Symbol	Parameter	min	max	Unit	Description
DCX	tast	Address setup time	0	-	ns	-
	taht	Address hold time (Write/Read)	10	-	ns	-
CSX	tchw	CSX "H" pulse width	0	-	ns	-
	tcs	Chip Select setup time (Write)	10	-	ns	-
	trcs	Chip Select setup time (Read ID)	45	-	ns	-
	trcsfm	Chip Select setup time (Read FM)	355	-	ns	-
WRX	tcsf	Chip Select Wait time (Write/Read)	10	-	ns	-
	twc	Write cycle	30	-	ns	-
	twrl	Write Control pulse L duration	10	-	ns	-
RDX (FM)	trcfm	Read Cycle (FM)	450	-	ns	When read from the Frame Memory
	trdhfm	Read Control H duration (FM)	90	-	ns	
	trdlfm	Read Control L duration (FM)	355	-	ns	
RDX (ID)	trc	Read cycle (ID)	160	-	ns	When read ID data
	trdh	Read Control pulse H duration	90	-	ns	
	trdl	Read Control pulse L duration	45	-	ns	
DB[17:0], DB[15:0], DB[8:0], DB[7:0]	tdst	Write data setup time	10	-	ns	CL = 30pF (maximum) CL = 8pF (minimum)
	tdht	Write data hold time	10	-	ns	
	trat	Read access time	-	40	ns	
	tratfm	Read access time	-	340	ns	
	trodh	Read output disable time	20	80	ns	

Table 5.2 MCU 8080 Interface Input Timing Parameters

5.3 16-bit Data Bus for 16-bit/pixel (RGB 5-6-5 bits input)

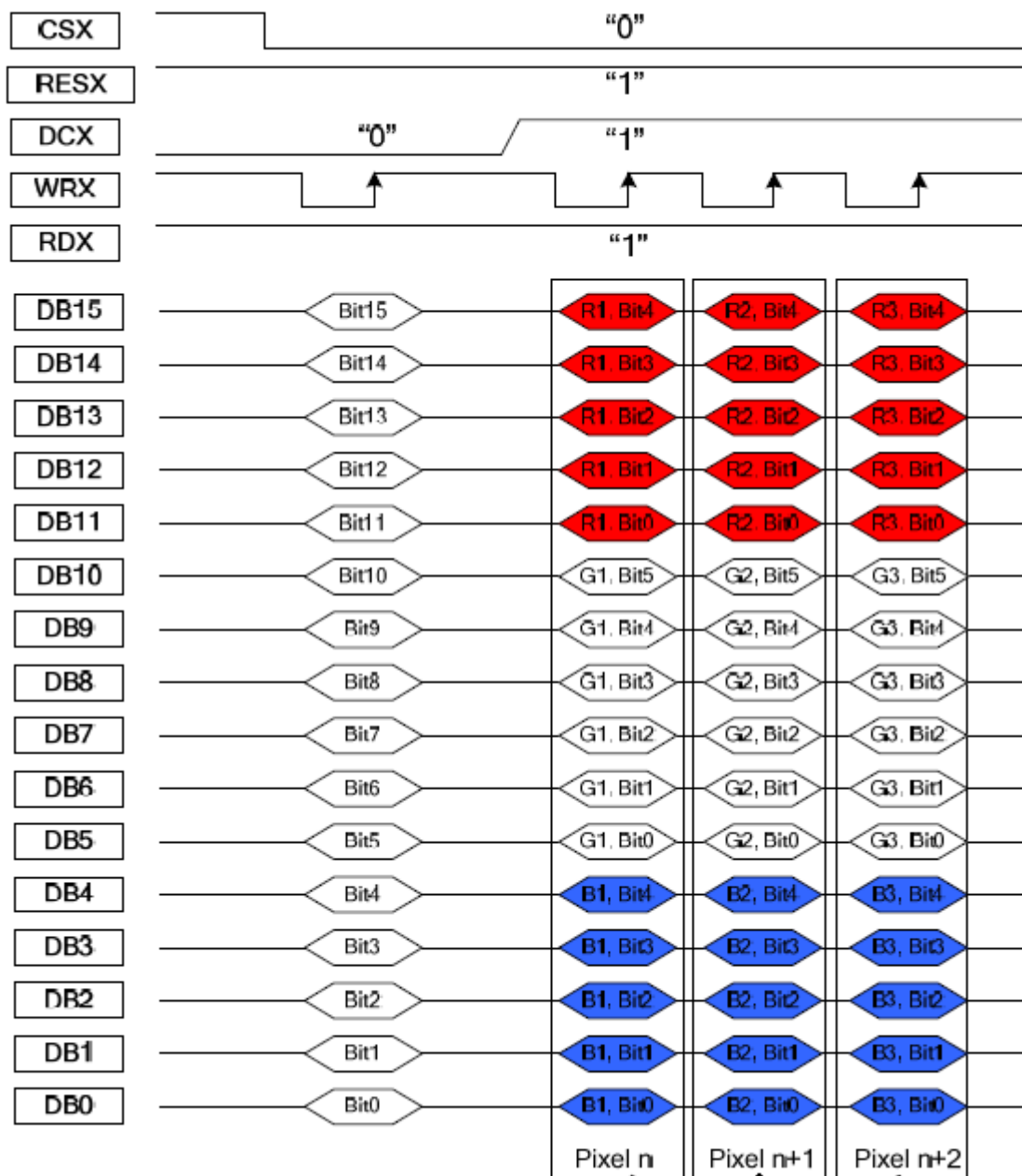

5.4 Reset timing

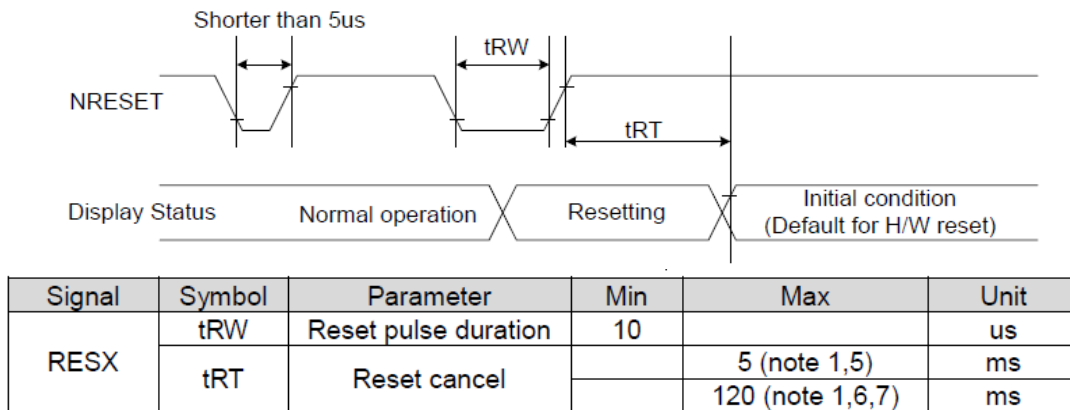
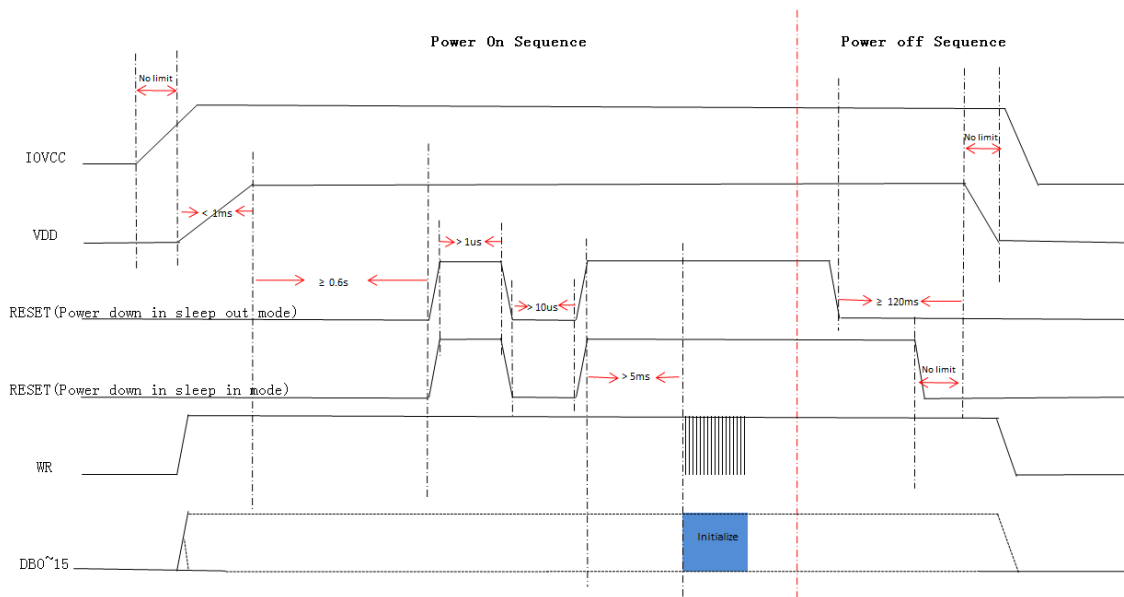

Figure 5.4 Reset Timing Diagram

5.5 POWER ON/OFF SEQUENCE

VDD and IOVCC can be applied or powered down in any order. During the Power Off sequence, if the LCD is in the Sleep Out mode, VDD and IOVCC must be powered down with minimum 120msec. If the LCD is in the Sleep In mode, VDD and IOVCC can be powered down with minimum 0msec after the RESET is released. CS can be applied at any timing or can be permanently grounded. RESET has high priority over CS.



Note:

- VCI Rising time $< 1ms$
- After Power on, delay min 0.6s first; Then do the operation of HW reset and initialization.
- Reset H-L-H and L-H is both accepted. (suggest using H-L-H mode)

6 Optical Characteristics

6.1 Driving the backlight condition (Transmissive mode)

Item	Symbol	Condition	Min	Typ	Max	Unit	Remark
View Angles	θT	CR \geq 10	25	35	-	Degree	Note2,3
	θB		25	35	-		
	θL		15	25	-		
	θR		15	25	-		
Contrast Ratio	CR	$\theta=0^\circ$	30	40	-		Note 3
Response Time	T _{ON}	25°C	-	30	50	ms	Note 4
	T _{OFF}						
Chromaticity	White	Backlight is on	x	0.223	0.273	0.323	Note 1,5
			y	0.235	0.285	0.335	
	Red		x	0.412	0.462	0.512	Note 1,5
			y	0.274	0.324	0.374	
	Green		x	0.235	0.285	0.335	Note 1,5
			y	0.418	0.468	0.518	
	Blue		x	0.114	0.164	0.214	Note 1,5
			y	0.082	0.132	0.182	
Uniformity	U		70	80		%	Note 6
NTSC			18	23		%	Note 5
Luminance	L		130	160		cd/m ²	Note 7
Flicker					-20	dB	
Crosstalk					3%		

Test Conditions:

1. I_F= 20mA, and the ambient temperature is 25°C.
2. The test systems refer to Note 1 and Note 2.
3. Chromaticity is just for reference, please judge by the actually measurement.
4. Flicker pattern(pixel inversion: 3dot inversion)



6.2 Not Driving the backlight condition(Reflective mode)

Item	Symbol	Condition	Min	Typ	Max	Unit		Remark
View Angles	θT	CR \geq 2	45	55	-	Degree	DMS-803 (Integrating sphere light)	Note2,3
	θB		45	55	-			
	θL		45	55	-			
	θR		45	55	-			
Contrast Ratio	CR	$\theta=0^\circ$	7	10	-		CM-3600A (2° view angle)	Note 3
Response Time	T _{ON}	25°C		20	40	ms	DMS-803 (Integrating sphere light)	Note 4
	T _{OFF}							
Chromaticity	White	Backlight is off	x	0.276	0.326	0.376	CM-3600A (2° view angle)	Note 1,5
			y	0.312	0.362	0.412		
	Red		x	0.434	0.484	0.534		Note 1,5
			y	0.289	0.339	0.389		
	Green		x	0.231	0.281	0.331		Note 1,5
			y	0.407	0.457	0.507		
	Blue		x	0.132	0.182	0.232		Note 1,5
			y	0.164	0.214	0.264		
Reflection ratio	U		5.48	6.45				Note 1
NTSC			15	19		%		Note 5
Flicker					-28	dB	DMS-803 (Parallel light)	Max in 0~60Hz

6.3 Not Driving the backlight condition(Reflective mode) test by CM-700D

Remark: this spec provides for customer reference

Item	Symbol	Condition	Min	Typ	Max	Unit	Testing equipment	Remark
Contrast Ratio	CR	$\theta=0^\circ$	7.5	10.5	-		CM-700d (2°view angle)	Note 3
Chromaticity	White	x	Backlight is off	0.268	0.318	0.368	CM-700d (2°view angle)	Note 1,5
		y		0.309	0.359	0.409		
	Red	x		0.432	0.482	0.532		Note 1,5
		y		0.293	0.343	0.393		
	Green	x		0.227	0.277	0.327		Note 1,5
		y		0.408	0.458	0.508		
	Blue	x		0.128	0.178	0.228		Note 1,5
		y		0.162	0.212	0.262		
Reflection ratio	U		5.0	5.8		%		
NTSC			15.5	19.5		%		

Test Conditions:

1. $I_F=20$ mA, and the ambient temperature is 25°C.
2. The test systems refer to Note 1 and Note 2.
3. Chromaticity is just for reference, please judge by the actually measurement.
4. Flicker pattern (pixel inversion: 3dot inversion)

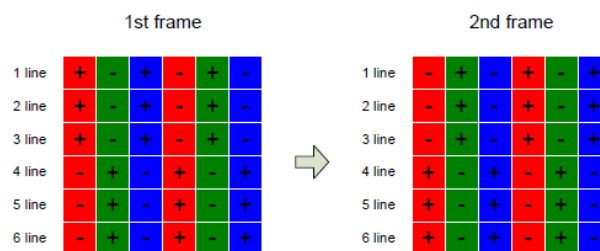

Note 1: Definition of optical measurement system.

1. Transmissive mode: The optical characteristics should be measured in dark room. After 5 Minutes operation, the optical properties are measured at the center point of the LCD screen. All input terminals LCD panel must be ground when measuring the center area of the panel.

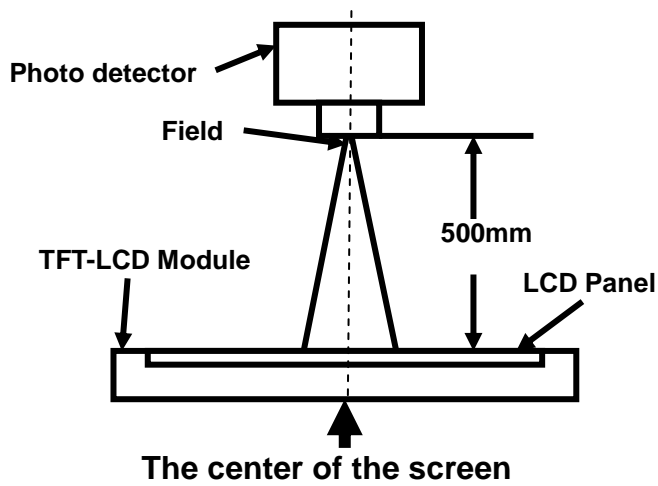

2.Reflective mode

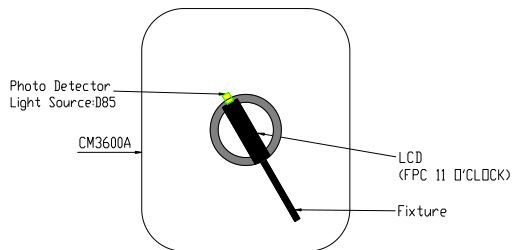

Item	Photo detector	Field
Chromaticity	CM-3600A (2° view angle)	
Contrast Ratio		
Viewing angle	DMS-803	
Flicker		
Response Time		
Reflective Ratio	CM-3600A (2° view angle)	

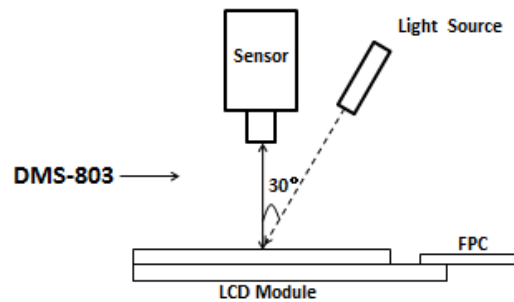
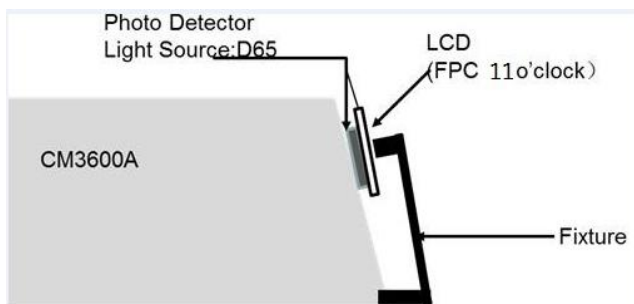

Note 2: Definition of viewing angle range and measurement system.

viewing angle is measured at the center point of the LCD.

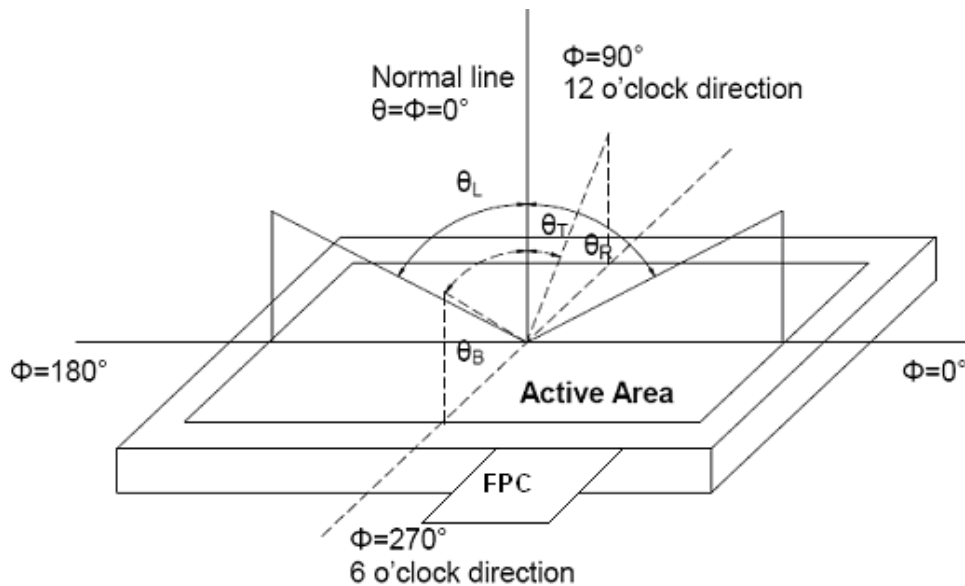

Note 3: Definition of contrast ratio

$$\text{Contrast ratio (CR)} = \frac{\text{Luminance measured when LCD is on the "White" state}}{\text{Luminance measured when LCD is on the "Black" state}}$$

“White state “: The state is that the LCD should drive by V_{white} .

“Black state”: The state is that the LCD should drive by V_{black} .

V_{white} : To be determined V_{black} : To be determined.

Note 4: Definition of Response time

The response time is defined as the LCD optical switching time interval between “White” state and “Black” state. Rise time (T_{ON}) is the time between photo detector output intensity changed from 90% to 10%. And fall time (T_{OFF}) is the time between photo detector output intensity changed from 10% to 90%.

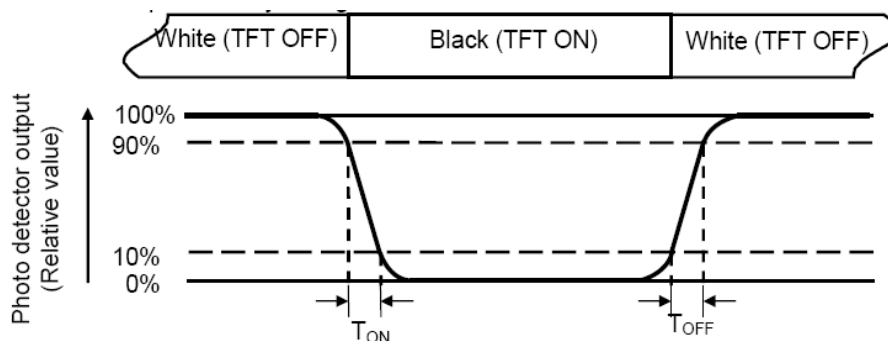

Note 5: Definition of color chromaticity (CIE1931)

- (1) Color coordinates measured at center point of LCD.
- (2) For reflective mode color chromaticity we need to test at least 3 different batches to make sure the stability of panel and it accepts reasonable change after we get the stability data.

Note 6: Definition of Luminance Uniformity

Active area is divided into 9 measuring areas (Refer Fig. 2). Every measuring point is placed at the center of each measuring area.

Luminance Uniformity (U) = L_{min} / L_{max}

L-----Active area length W----- Active area width

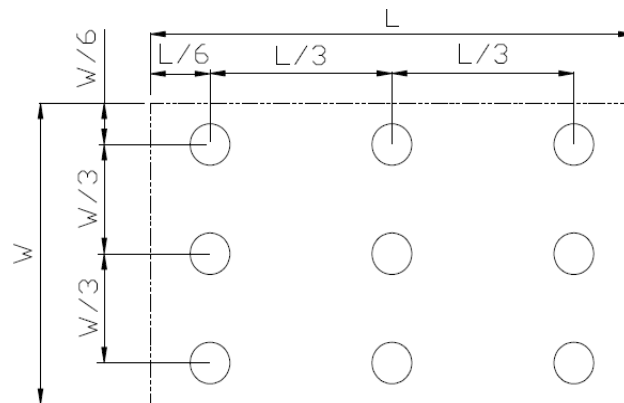

L_{max} : The measured Maximum luminance of all measurement position.

L_{min} : The measured Minimum luminance of all measurement position.

Note 7: Definition of Luminance:

Measure the luminance of white state at center point.

7 Environmental / Reliability Test

No	Test Item	Condition	Remarks
1	High Temperature Operation	Ta=+70°C, 240hrs	IEC60068-2-1:2007 GB2423.2-2008
2	Low Temperature Operation	Ta=-20°C, 240hrs	IEC60068-2-1:2007 GB2423.1-2008
3	High Temperature Storage	Ta=+85°C, 240hrs	IEC60068-2-1:2007 GB2423.2-2008
4	Low Temperature Storage	Ta=-40°C, 240hrs	IEC60068-2-1:2007 GB2423.1-2008
5	Storage at High Temperature and Humidity	Ta=+60°C, 90% RH 240 hours	IEC60068-2-78 :2001 GB/T2423.3—2006
6	Thermal Shock (non-operation)	-40°C 60 min~+85°C 60 min, Change time:5min, 50 Cycles	Start with cold temperature, End with high temperature, IEC60068-2-14:1984,GB 2423.22-2002
7	ESD	C=150pF, R=330Ω, 5points/panel Air:±6KV, 5times; Contact:±4KV, 5 times; (Environment: 15°C~35°C, 30%~60%, 86Kpa~106Kpa)	IEC61000-4-2:2001 GB/T17626.2-2006
8	Vibration Test	Frequency range:10~55Hz, Stroke:1.5mm Sweep:10Hz~55Hz~10Hz 2 hours for each direction of X.Y.Z.	IEC60068-2-6:1982 GB/T2423.10—1995
9	Mechanical Shock (Non OP)	60G 6ms, ±X,±Y,±Z 3times, for each direction	IEC60068-2-27:1987 GB/T2423.5—1995
10	Package Drop Test	Height:60cm, 1corner,3edges,6surfaces	IEC60068-2-32:1990 GB/T2423.8—1995
11	Image sticking test	40°C 6 hours, release 30min,50% gray	

Note1: Ta is the ambient temperature of sample.

Note2: Before cosmetic and function test, the product must have enough recovery time, at least 2 hours at room temperature.

Note 3: In the standard condition, there shall be no practical problem that may affect the display function. After the reliability test, the product only guarantees operation, but don't guarantee all of the cosmetic specification.

Note 4: Image sticking test is as below.

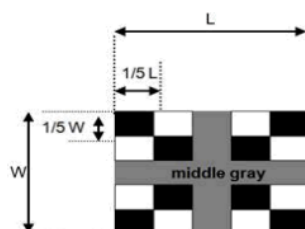

9 Packing Drawing

Packaging Material

No	Item	Model (Material)	Dimensions(mm)	Unit Weight(Kg)	Quantity	Remark
1	LCM Module	TBD	TBD	TBD	TBD	TBD
2	Tray	TBD	TBD	TBD	TBD	TBD
3	Dust-Proof Bag	TBD	TBD	TBD	TBD	TBD
4	BOX	TBD	TBD	TBD	TBD	TBD
5	Carton	TBD	TBD	TBD	TBD	TBD
6	Total Weight	TBD				

Packing Drawing

TBD

10 Precautions for Use of LCD Modules

10.1 Handling Precautions

10.1.1 The display panel is made of glass. Do not subject it to a mechanical shock by dropping it from a high place, etc.

10.1.2 If the display panel is damaged and the liquid crystal substance inside it leaks out, be sure not to get any in your mouth, if the substance comes into contact with your skin or clothes, promptly wash it off using soap and water.

10.1.3 Do not apply excessive force to the display surface or the adjoining areas since this may cause the color tone to vary.

10.1.4 The polarizer covering the display surface of the LCD module is soft and easily scratched. Handle this polarizer carefully.

10.1.5 If the display surface is contaminated, breathe on the surface and gently wipe it with a soft dry cloth. If still not completely clear, moisten cloth with one of the following solvents:

- Isopropyl alcohol
- Ethyl alcohol

Solvents other than those mentioned above may damage the polarizer. Especially, do not use the following:

- Water
- Ketone
- Aromatic solvents

10.1.6 Do not attempt to disassemble the LCD Module.

10.1.7 If the logic circuit power is off, do not apply the input signals.

10.1.8 To prevent destruction of the elements by static electricity, be careful to maintain an optimum work environment.

10.1.8.1 Be sure to ground the body when handling the LCD Modules.

10.1.8.2 Tools required for assembly, such as soldering irons, must be properly ground.

10.1.8.3 To reduce the amount of static electricity generated, do not conduct assembly and other work under dry conditions.

10.1.8.4 The LCD Module is coated with a film to protect the display surface. Be care when peeling off this protective film since static electricity may be generated.

10.2 Storage precautions

10.2.1 When storing the LCD modules, avoid exposure to direct sunlight or to the light of fluorescent lamps.

10.2.2 The LCD modules should be stored under the storage temperature range. If the LCD modules will be stored for a long time, the recommend condition is:

Temperature : 0°C ~ 40°C Relatively humidity: ≤80%

10.2.3 The LCD modules should be stored in the room without acid, alkali and harmful gas.

10.3 Transportation Precautions

10.3.1 The LCD modules should be no falling and violent shocking during transportation, and also should avoid excessive press, water, damp and sunshine.

10.4 Bar Code definition on module