



---

---

## Product Specification

Part Name: 7 inch TFT Display Module

Customer Part ID:

Topovision Part ID: TVT0700PA-PCB

Ver: A

Customer:
Approved by

From: Topovision Technology Co., Ltd.
Approved by

Notes:

1. Please contact Topovision Technology Co., Ltd. before assigning your product based on this module specification
2. The information contained herein is presented merely to indicate the characteristics and performance of our products. No responsibility is assumed by Topovision Technology Co., Ltd. for any intellectual property claims or other problems that may result from application based on the module described herein.

## Revision History

Rev.	Date	Contents	Written	Approved
A	2018/08/15	Preliminary Specification	ZHENG	YUAN

### Special Notes

Note1.	

## Table of Contents

1	General Description.....	4
3	Mechanical Drawings.....	5
4	Module Interface.....	5
5	Application Circuit.....	7
	Backlight recommended circuit.....	7
6	Absolute Maximum Ratings.....	8
7	Electrical Specification.....	8
8	AC Characteristics.....	8
9	Command Table.....	8
10	Recommended Setting and Initialization Flow for Reference.....	8
11	Optical Specifications.....	8
	11.1 Optical Specifications.....	8
	11.2 Definition of Response Time.....	9
	11.3 Definition of Contrast Ratio.....	10
	11.4 Definition of Viewing Angles.....	10
	11.5 Definition of Color Appearance.....	10
	11.6 Definition of Surface Luminance, Uniformity and Transmittance.....	11
12	Quality Assurance.....	11
	12.1 Purpose.....	11
	12.2 Agreement Items.....	11
	12.3 Standard of the Product Visual Inspection.....	11
	12.4 Inspection Specification.....	12
	12.5 Classification of Defects.....	16
	12.6 Identification/marketing criteria.....	16
	12.7 Packing.....	16
13	Reliability Specification.....	16
14	Precautions and Warranty.....	17
	14.1 Safety.....	17
	14.2 Handling.....	17
	14.3 Operation.....	17
	14.4 Static Electricity.....	18
	14.5 Limited Warranty.....	18
15	Packaging.....	18
16	Prior Consult Matter.....	18

## 1 General Description

This display module is a transmissive type color active matrix TFT(Thin Film Transistor) liquid crystal display (LCD) that uses amorphous silicon TFT as a switching device. This module is composed of a TFT LCD module, a driver circuit, and a back-light unit. The resolution of a 7" contains 1024(RGB)X600 dots and can display up to 16.7M colors.

## 2 Module Parameter

Features	Details	Unit
Display Size(Diagonal)	7	inch
LCD type	$\alpha$ -Si TFT	-
Display Mode	IPS / Transmissive / Normally Black	-
Resolution	1024RGB x 600	-
View Direction	All	Best image
Module Outline	160.97(H) × 110.95(V) (Note 1 )	mm
TP Outline	N/A	mm
TP Viewing Area	165 (H) × 100(V)	mm
TP Active Area	154.21 (H) × 85.92(V)	mm
Active Area	154.21 (H) × 85.92(V)	mm
Viewing Area	N/A	mm
Display Colors	16.7M	-
Interface	HDMI+USB2.0	-
Driver IC	N/A	-
Operating Temperature	0~50	°C
Storage Temperature	-10~60	°C
Weight	TBD	g

Note 1: Excluding hooks, posts , FPC/FPC tail etc.

### 3 Mechanical Drawings

#### Board:

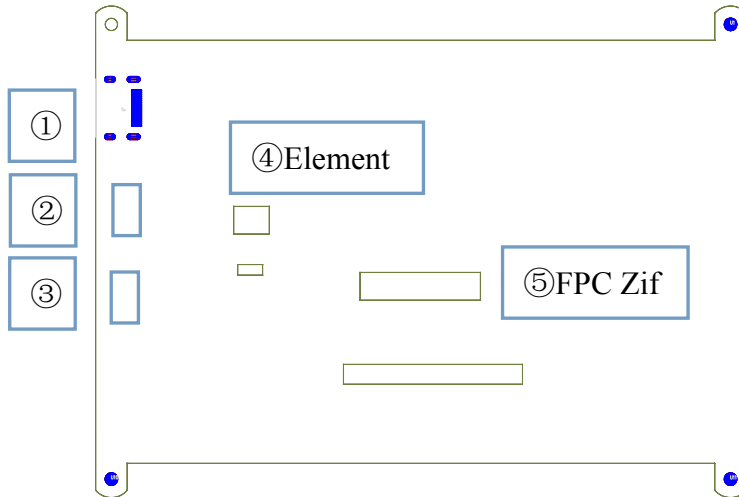

#### Screen:

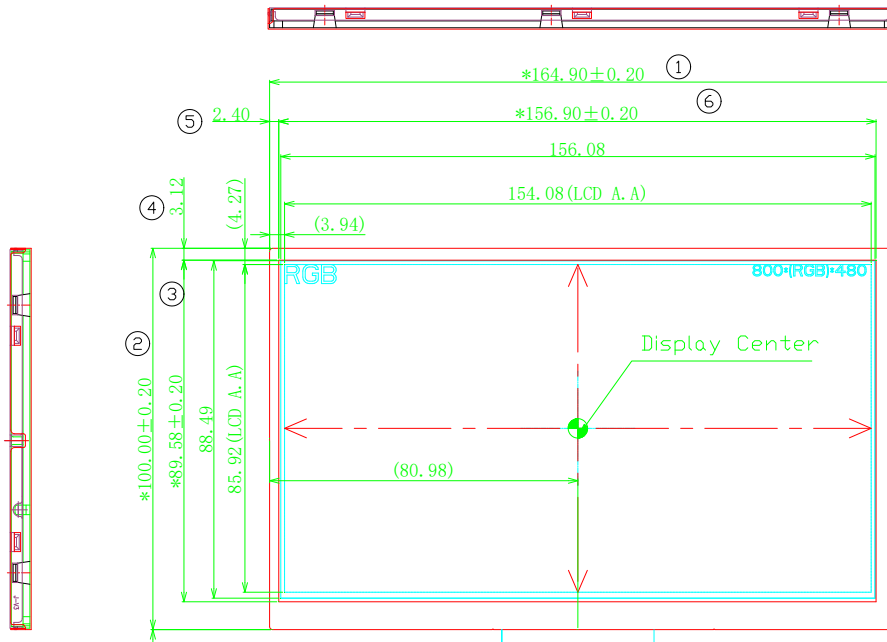

## 4 Module Interface

NO	SYMBOL	FUNCTION
1	Input	HDMI signal input, standard HDMI type A socket
2	Input	Power input, micro USB socket
3	Input	Touch input, micro USB socket
4	N/A	Element area
5	Output	Screen FPC connector, 50 pins, RGB data signal output

## 5 Application Circuit

### Backlight recommended circuit

Motherboard driver backlight is need constant current circuit, if the rated voltage screen after light brightness difference. Current and power consumption of the machine are inconsistent, so recommend a backlight driving circuit is best rated current. It is recommended to use IC (SGM3752). The reference circuit is as follows:

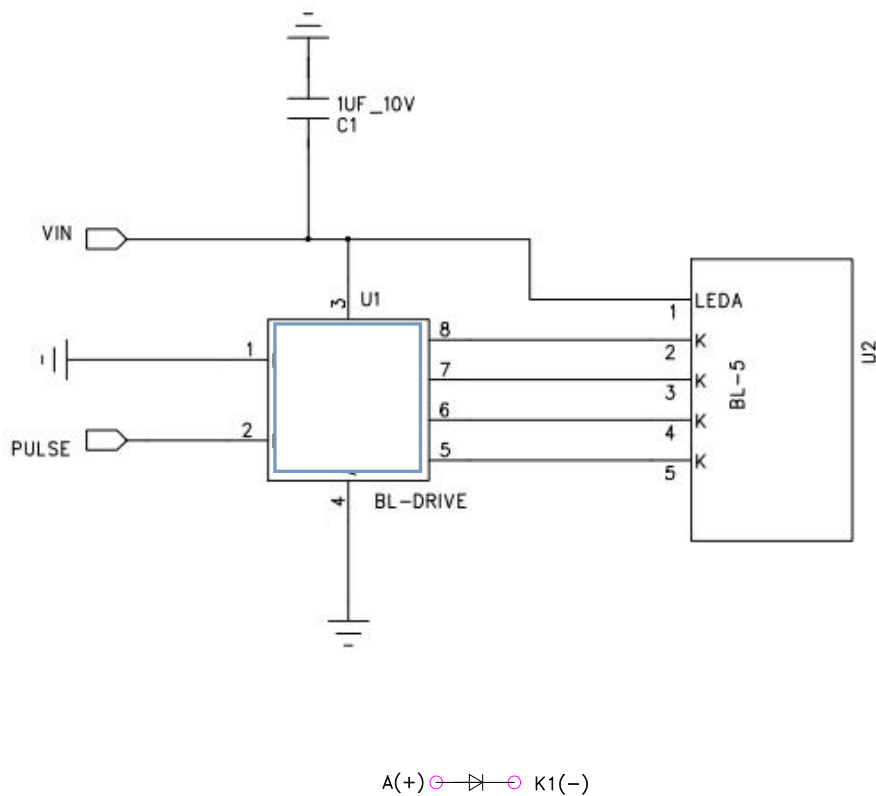

Note: constant current circuit for every LED, and though LED lamp current is less than 20mA. Recommend between 15mA and 20 mA for every LED.

## 6 Absolute Maximum Ratings

VSS=0V, Ta=25°C

Item		Symbol	Min.	Max.	Unit
Supply Voltage	Power supply	VDD	-0.3	+5	V
	Analog	-	-	-	V
	IO	IOVDD	-0.3	3.3	V
Input Voltage		V <sub>i</sub>	-0.3	IOVDD+0.3	V
Storage temperature		T <sub>stg</sub>	-10	+60	°C
Operating temperature		T <sub>op</sub>	-0	+50	°C
Storage humidity		H <sub>stg</sub>	10	Note 1	%RH
Operating humidity		H <sub>op</sub>	10	Note 1	%RH

Note 1: 90%RH max, If Ta is below 50°C; 60%RH max, If Ta is over 60°C.

## 7 Electrical Specification

Please refer to IC datasheet.

## 8 AC Characteristics

Reset timing and interface timing:

Please refer to IC datasheet.

## 9 Command Table

Please refer to IC datasheet.

## 10 Recommended Setting and Initialization Flow for Reference

Please refer to attached file.

## 11 Optical Specifications

### 11.1 Optical Specifications

Ta=25°C, VDD=2.8V, TN LC+ Polarizer

Backlight On (Transmissive)	Item	Symbol	Condition	Specification			Unit
				Min.	Typ.	Max.	
	Luminance on surface( $I_f=20\text{mA}$ )	L <sub>v</sub>	Normally viewing angle $\theta_x = \theta_y = 0^\circ$	250	300	-	cd/m <sup>2</sup>
	Contrast ratio	CR		-	600	-	-
	Response time	T <sub>R</sub>	-	10	20	ms	
		T <sub>F</sub>	-	-	20		30

Chromaticity Transmissive	Red	$X_R$	-	0.614	0.644	0.674	-		
		$Y_R$		0.290	0.320	0.350	-		
	Green	$X_G$		0.270	0.300	0.330	-		
		$Y_G$		0.540	0.570	0.600	-		
	Blue	$X_B$		0.104	0.134	0.164	-		
		$Y_B$		0.097	0.127	0.157	-		
	White	$X_W$		0.267	0.297	0.327	-		
		$Y_W$		0.302	0.332	0.362	-		
	Viewing Angle	Horizontal		$\theta_{X+}$	Center $CR \geq 10$	-	80	-	Deg.
				$\theta_{X-}$		-	80	-	
		Vertical		$\theta_{Y+}$		-	80	-	
				$\theta_{Y-}$		-	80	-	
NTSC Ratio(Gamut)		-	-	-	60	-	%		

## 11.2 Definition of Response Time

### 11.2.1 Normally Black Type (Negative)

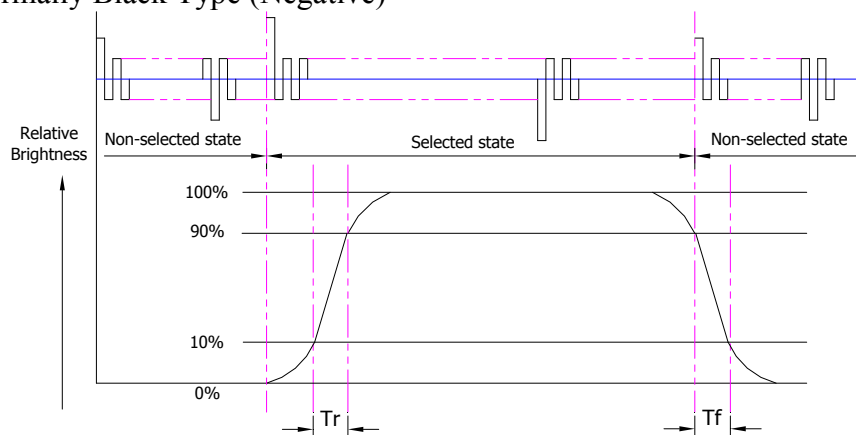

$T_r$  is the time it takes to change from non-selected state with relative luminance 10% to selected state with relative luminance 90%;

$T_f$  is the time it takes to change from selected state with relative luminance 90% to non-selected state with relative luminance 10%.

### 11.2.2 Normally White Type (Positive)

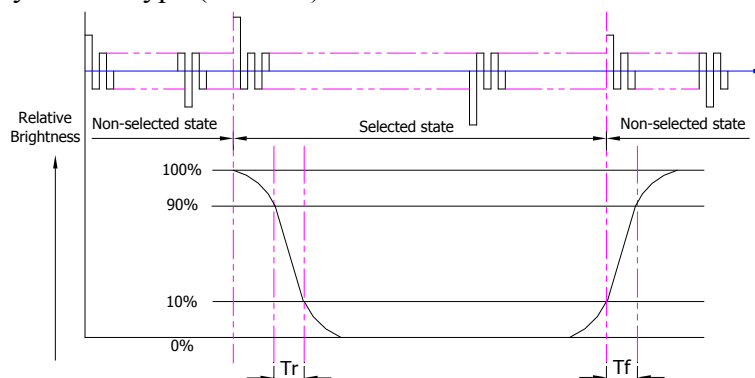

$T_r$  is the time it takes to change from non-selected state with relative luminance

90% to selected state with relative luminance 10%;

Tf is the time it takes to change from selected state with relative luminance 10% to non-selected state with relative luminance 90%;

### 11.3 Definition of Contrast Ratio

Contrast is measured perpendicular to display surface in reflective and transmissive mode. The measurement condition is:

Measuring Equipment	BM-7 or EQUI
Measuring Point Diameter	3mm//1mm
Measuring Point Location	Active Area centre point
Test pattern	A: All Pixels white
	B: All Pixel black
Contrast setting	Maximum

Definitions: CR (Contrast) = Luminance of White Pixel / Luminance of Black Pixel

### 11.4 Definition of Viewing Angles

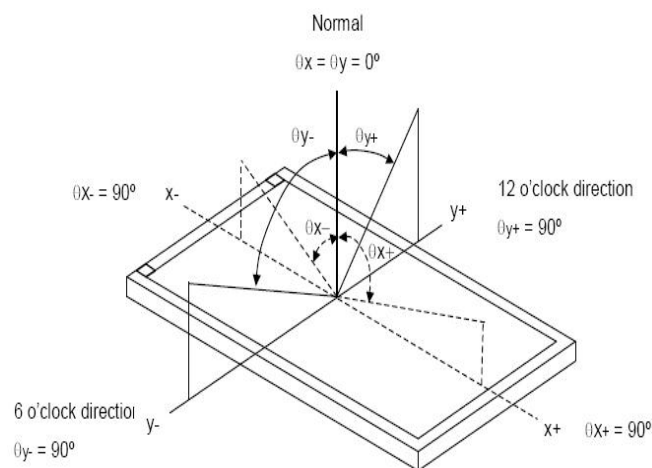

Measuring machine: LCD-5100 or EQUI

### 11.5 Definition of Color Appearance

R,G,B and W are defined by (x, y) on the IE chromaticity diagram

NTSC=area of RGB triangle/area of NTSC triangleX100%

Measuring picture: Red, Green, Blue and White (Measuring machine: BM-7)

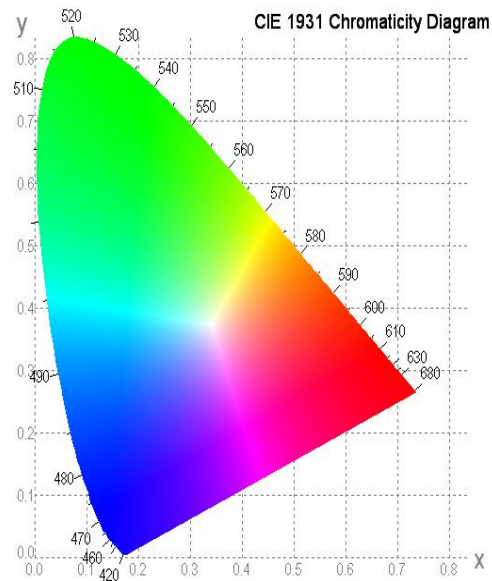

### 11.6 Definition of Surface Luminance, Uniformity and Transmittance

Using the transmissive mode measurement approach, measure the white screen luminance of the display panel and backlight.

11.6.1 Surface Luminance:  $LV = \text{average (LP1:LP9)}$

11.6.2 Uniformity =  $\text{Minimal (LP1:LP9) / Maximal (LP1:LP9) * 100\%}$

11.6.3 Transmittance =  $LV \text{ on LCD} / LV \text{ on Backlight} * 100\%$

Note :Measuring machine:BM-7

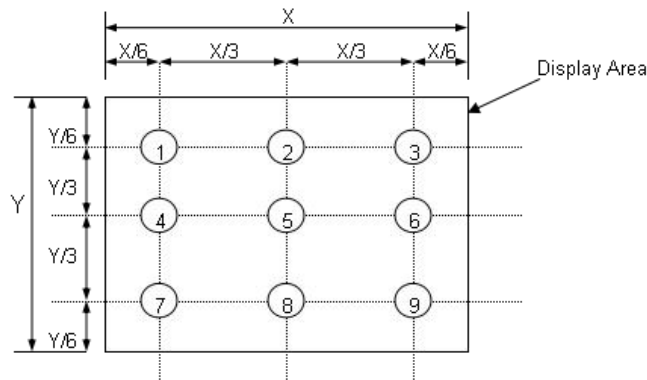

## 12 Quality Assurance

### 12.1 Purpose

This standard for Quality Assurance assures the quality of LCD module products supplied to customer by C.I.E display.

### 12.2 Agreement Items

C.I.E and customer shall negotiate if the following situation occurs:

12.2.1 Discrepancies between C.I.E 's QA standards and customer's QA standards.

12.2.2 Additional requirement to be added in product specification.

12.2.3 Any other special problem.

### 12.3 Standard of the Product Visual Inspection

### 12.3.1 Appearance inspection:

12.3.1.1 The inspection must be under illumination about 1000 – 1500 lx, and the distance of view must be at  $30\text{cm} \pm 2\text{cm}$ .

12.3.1.2 The viewing angle should be  $45^\circ$  from the vertical line without reflection light or follows customer's viewing angle specifications.

12.3.1.3 Definition of area: A Zone: Active Area, B Zone: Viewing Area.

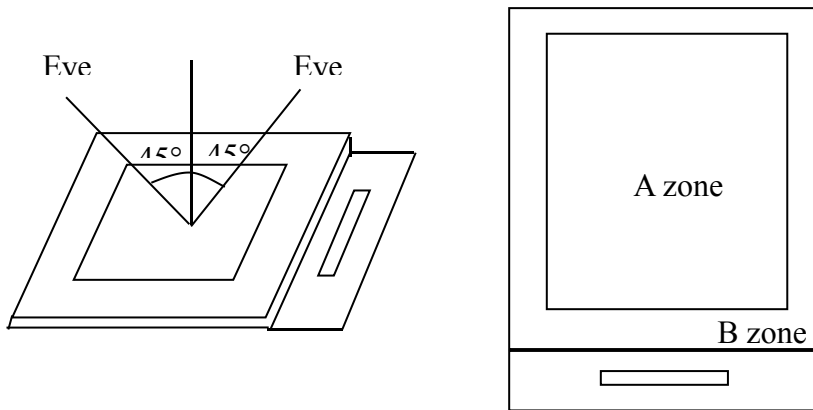

12.3.2 Basic principle: A set of sample to indicate the limit of acceptable quality level must be discussed by both C.I.E and customer when there is any dispute happened.

### 12.4 Inspection Specification

Sampling plan according to GB/T2828.1-2012/ISO 2859-1: 1999 and ANSI/ASQC

Z1.4-1993, normal level 2 and based on:

Major defect: AQL 0.65

Minor defect: AQL 1.5

No.	Item	Criteria (Unit: mm)																		
01	Black / White spot Foreign material (Round type) Pinholes Stain Particles inside cell. (Minor defect)	<div style="display: flex; justify-content: space-around; align-items: center;"> <table border="1" style="border-collapse: collapse;"> <thead> <tr> <th>Size</th> <th>Area</th> <th>Acc. Qty</th> </tr> </thead> <tbody> <tr> <td><math>\phi \leq 0.10</math></td> <td></td> <td>Ignore</td> </tr> <tr> <td><math>0.10 &lt; \phi \leq 0.15</math></td> <td></td> <td>2</td> </tr> <tr> <td><math>0.15 &lt; \phi \leq 0.20</math></td> <td></td> <td>1</td> </tr> <tr> <td><math>0.20 &lt; \phi</math></td> <td></td> <td>0</td> </tr> <tr> <td>Total</td> <td></td> <td>2 no include <math>\phi \leq 0.10</math></td> </tr> </tbody> </table> <p>Distance between 2 defects should more than 5mm apart.</p> </div>	Size	Area	Acc. Qty	$\phi \leq 0.10$		Ignore	$0.10 < \phi \leq 0.15$		2	$0.15 < \phi \leq 0.20$		1	$0.20 < \phi$		0	Total		2 no include $\phi \leq 0.10$
Size	Area	Acc. Qty																		
$\phi \leq 0.10$		Ignore																		
$0.10 < \phi \leq 0.15$		2																		
$0.15 < \phi \leq 0.20$		1																		
$0.20 < \phi$		0																		
Total		2 no include $\phi \leq 0.10$																		
02	Black and White line Scratch																			

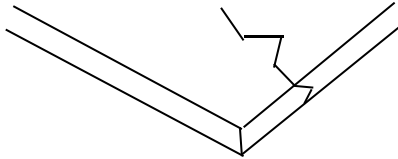
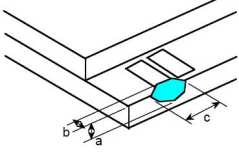
No.	Item	Criteria (Unit: mm)															
	Foreign material (Line type) (Minor defect)	<table border="1" data-bbox="643 510 1268 797"> <thead> <tr> <th>Length</th> <th>Width</th> <th>Acc. Qty</th> </tr> </thead> <tbody> <tr> <td>/</td> <td><math>W \leq 0.03</math></td> <td>Ignore</td> </tr> <tr> <td><math>L \leq 2</math></td> <td><math>0.03 &lt; W \leq 0.05</math></td> <td>1</td> </tr> <tr> <td>/</td> <td><math>0.05 &lt; W</math></td> <td>0</td> </tr> <tr> <td colspan="2">Total</td> <td>1</td> </tr> </tbody> </table> <p data-bbox="582 853 1337 981">Distance between 2 defects should more than 3mm apart. Scratches not viewable through the back of the display are acceptable.</p>	Length	Width	Acc. Qty	/	$W \leq 0.03$	Ignore	$L \leq 2$	$0.03 < W \leq 0.05$	1	/	$0.05 < W$	0	Total		1
Length	Width	Acc. Qty															
/	$W \leq 0.03$	Ignore															
$L \leq 2$	$0.03 < W \leq 0.05$	1															
/	$0.05 < W$	0															
Total		1															
03	Glass Crack (Minor defect)	 <p data-bbox="582 1238 1428 1368">LCD with extensible crack line is unacceptable(When press the cracked LCD area, the line will expand, we define it is extensible crack line)</p>															
04	Glass Chipping Pad Area: (Minor defect)	 <table border="1" data-bbox="774 1458 1243 1559"> <thead> <tr> <th>Length and Width</th> <th>Acc. Qty</th> </tr> </thead> <tbody> <tr> <td><math>c &lt; 5.0, b &lt; 0.4</math></td> <td>Ignore</td> </tr> </tbody> </table>	Length and Width	Acc. Qty	$c < 5.0, b < 0.4$	Ignore											
Length and Width	Acc. Qty																
$c < 5.0, b < 0.4$	Ignore																

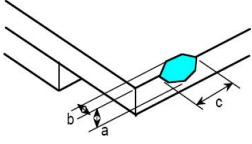
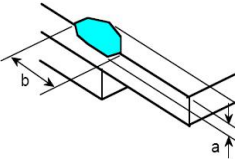
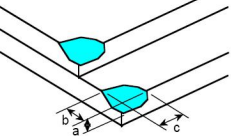
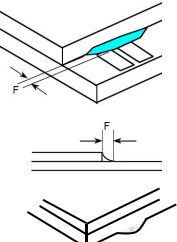
No.	Item	Criteria (Unit: mm)										
05	Glass Chipping Rear of Pad Area: (Minor defect) 	<table border="1" data-bbox="774 353 1243 600"> <thead> <tr> <th>Length and Width</th> <th>Acc. Qty</th> </tr> </thead> <tbody> <tr> <td><math>c &gt; 3.0, b &lt; 1.0</math></td> <td>1</td> </tr> <tr> <td><math>c &lt; 3.0, b &lt; 1.0</math></td> <td>2</td> </tr> <tr> <td><math>c &lt; 3.0, b &lt; 0.5</math></td> <td>4</td> </tr> <tr> <td colspan="2" style="text-align: center;"><math>a &lt; \text{Glass Thickness}</math></td> </tr> </tbody> </table>	Length and Width	Acc. Qty	$c > 3.0, b < 1.0$	1	$c < 3.0, b < 1.0$	2	$c < 3.0, b < 0.5$	4	$a < \text{Glass Thickness}$	
Length and Width	Acc. Qty											
$c > 3.0, b < 1.0$	1											
$c < 3.0, b < 1.0$	2											
$c < 3.0, b < 0.5$	4											
$a < \text{Glass Thickness}$												
06	Glass Chipping Except Pad Area: (Minor defect) 	<table border="1" data-bbox="774 857 1243 1003"> <thead> <tr> <th>Length and Width</th> <th>Acc. Qty</th> </tr> </thead> <tbody> <tr> <td><math>c \leq 0.6, b &lt; 5.0</math></td> <td>Ignore</td> </tr> <tr> <td colspan="2" style="text-align: center;"><math>a &lt; \text{Glass Thickness}</math></td> </tr> </tbody> </table>	Length and Width	Acc. Qty	$c \leq 0.6, b < 5.0$	Ignore	$a < \text{Glass Thickness}$					
Length and Width	Acc. Qty											
$c \leq 0.6, b < 5.0$	Ignore											
$a < \text{Glass Thickness}$												
07	Glass Corner Chipping: (Minor defect) 	<table border="1" data-bbox="774 1249 1243 1447"> <thead> <tr> <th>Length and Width</th> <th>Acc. Qty</th> </tr> </thead> <tbody> <tr> <td><math>c &lt; 2.0, b &lt; 1.5</math></td> <td>Ignore</td> </tr> <tr> <td><math>c &lt; 1.5, b &lt; 2</math></td> <td>Ignore</td> </tr> <tr> <td colspan="2" style="text-align: center;"><math>a &lt; \text{Glass Thickness}</math></td> </tr> </tbody> </table>	Length and Width	Acc. Qty	$c < 2.0, b < 1.5$	Ignore	$c < 1.5, b < 2$	Ignore	$a < \text{Glass Thickness}$			
Length and Width	Acc. Qty											
$c < 2.0, b < 1.5$	Ignore											
$c < 1.5, b < 2$	Ignore											
$a < \text{Glass Thickness}$												
08	Glass Burr: (Minor defect) 	Glass burr don't affect assemble and module dimension. <table border="1" data-bbox="774 1653 1243 1753"> <thead> <tr> <th>Length</th> <th>Acc. Qty</th> </tr> </thead> <tbody> <tr> <td><math>F &lt; 0.5</math></td> <td>Ignore</td> </tr> </tbody> </table>	Length	Acc. Qty	$F < 0.5$	Ignore						
Length	Acc. Qty											
$F < 0.5$	Ignore											

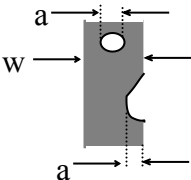
No.	Item	Criteria (Unit: mm)								
09	FPC Defect: (Minor defect) 	9.1 Dent, pinhole width $a < w/3$ . (w: circuitry width.) 9.2 Open circuit is unacceptable. 9.3 No oxidation, contamination and distortion.								
10	Bubble on Polarizer (Minor defect)	<table border="1" data-bbox="772 624 1241 824"> <thead> <tr> <th>Diameter</th> <th>Acc. Qty</th> </tr> </thead> <tbody> <tr> <td><math>\varphi \leq 0.10</math></td> <td>Ignore</td> </tr> <tr> <td><math>0.1 &lt; \varphi \leq 0.2</math></td> <td>1</td> </tr> <tr> <td><math>0.2 &lt; \varphi</math></td> <td>None</td> </tr> </tbody> </table>	Diameter	Acc. Qty	$\varphi \leq 0.10$	Ignore	$0.1 < \varphi \leq 0.2$	1	$0.2 < \varphi$	None
Diameter	Acc. Qty									
$\varphi \leq 0.10$	Ignore									
$0.1 < \varphi \leq 0.2$	1									
$0.2 < \varphi$	None									
11	Dent on Polarizer (Minor defect)	<table border="1" data-bbox="772 848 1241 1048"> <thead> <tr> <th>Diameter</th> <th>Acc. Qty</th> </tr> </thead> <tbody> <tr> <td><math>\varphi \leq 0.10</math></td> <td>Ignore</td> </tr> <tr> <td><math>0.1 &lt; \varphi \leq 0.2</math></td> <td>1</td> </tr> <tr> <td><math>0.2 &lt; \varphi</math></td> <td>None</td> </tr> </tbody> </table>	Diameter	Acc. Qty	$\varphi \leq 0.10$	Ignore	$0.1 < \varphi \leq 0.2$	1	$0.2 < \varphi$	None
Diameter	Acc. Qty									
$\varphi \leq 0.10$	Ignore									
$0.1 < \varphi \leq 0.2$	1									
$0.2 < \varphi$	None									
12	Bezel	12.1 No rust, distortion on the Bezel. 12.2 No visible fingerprints, stains or other contamination.								
13	Touch Panel	D: Diameter W: width L: length 13.1 Spot: $D \leq 0.20$ is acceptable $0.20 < D \leq 0.3$ , acceptable QTY, 3 2dots are acceptable and the distance between defects should more than 10 mm. $D > 0.3$ is unacceptable 13.2 Dent: $D > 0.30$ is unacceptable 13.3 Scratch: $W \leq 0.03$ , $L \leq 10$ is acceptable, $0.03 < W \leq 0.10$ , $L \leq 10$ , acceptable QTY, 3 Distance between 2 defects should more than 10 mm. $W > 0.10$ is unacceptable.								
14	PCB	14.1 No distortion or contamination on PCB terminals. 14.2 All components on PCB must same as documented on the BOM/component layout. 14.3 Follow IPC-A-600F.								
15	Soldering	Follow IPC-A-610C standard								

No.	Item	Criteria (Unit: mm)
16	Electrical Defect (Major defect)	The below defects must be rejected. 16.1 Missing vertical / horizontal segment, 16.2 Abnormal Display. 16.3 No function or no display. 16.4 Current exceeds product specifications. 16.5 LCD viewing angle defect. 16.6 No Backlight. 16.7 Dark Backlight. 16.8 Touch Panel no function. 16.9 Dark Dot –one Allowed. 16.10 Bright Dot – one Allowed. Remark: 1. A pixel defect is acceptable if one color is none functional and causes a bright dot. The display may have one case where one color is out and cause a dark dot. 2. Bright dot caused by scratch and foreign object accords to item1.

Remark: Visual and cosmetic defects are rejectable only if these fall within the LCD viewing area.

### 12.5 Classification of Defects

Visual defects (Except no / wrong label) are treated as minor defect and electrical defect is major.

### 12.6 Identification/marking criteria

Any unit with illegible / wrong /double or no marking/ label shall be rejected.

### 12.7 Packing

12.7.1 There should be no damage of the outside carton box, each packaging box should has label in the correct location per packing drawing requirement.

12.7.2 All direct package materials shall offer ESD protection.

## 13 Reliability Specification

Item	Condition	Cycle Time	Quantity	Remark
Constant Temp. and Constant Humidity Operation Test	+40 ± 3°C, 90 ± 3%RH	120hrs	--	*1
High Temp. Operation Test	+50 ± 3°C	120hrs	--	
Low Temp. Operation Test	0 ± 3°C	120hrs	--	
Thermal Shock Test	0 ± 3°C (30min) +50 ± 3°C (30min)	10cycles	--	
ESD Test(end product)	150pF, 330Ω, ±2KV,	10times	--	*2, *3

	Contact			
	150pF, 330Ω, ±6KV, Air			
Vibration Test (for packaging)	Frequency: 10Hz to 55Hz to10Hz,Swing: 1.5mm,time: X,Y,Z each 2H.	6hrs	One inner carton	*4

Note 1. For humidity test, DI water should be used.

Inspection Standard: Inspect after 1-2hrs storage at room temperature, the sample shall be free from the following defects:

- Air bubble in the LCD
- Seal Leakage
- Non-display
- Missing Segment
- Glass Crack
- IDD is greater than twice initial value.
- Others as per QA Inspection Criteria

Note 2. No defect is allowed after testing

The End Product ESD value is only indicative and depends on customer ESD protection design for the whole system.

Note 3. ESD should be applied to LCD glass panel, not other areas (such as on IC and so on) IDD should be within twice initial value.

In case of malfunction defect caused by ESD damage, if it would be recovered to normal state after resetting, it would be judged as a good part.

Note 4. Only upon request.

## 14 Precautions and Warranty

### 14.1 Safety

14.1.1 The liquid crystal in the LCD is poisonous. Do not put it in your mouth. If the liquid crystal touches your skin or clothes, wash it off immediately using soap and water.

14.1.2 Since the liquid crystal cells are made of glass, do not apply strong impact on them.

Handle with care.

### 14.2 Handling

14.2.1 Reverse and use within ratings in order to keep performance and prevent damage.

14.2.2 Do not wipe the polarizer with dry cloth, as it might cause scratch. If the surface of the LCD needs to be cleaned, wipe it swiftly with cotton or other soft cloth soaked with petroleum IPA, do not use other chemicals.

### 14.3 Operation

14.3.1 Do not drive LCD with DC voltage

14.3.2 Response time will increase below lower temperature

14.3.3 Display may change color with different temperature

14.3.4 Mechanical disturbance during operation, such as pressing on the display area, may cause the segments to appear “fractured”.

#### **14.4 Static Electricity**

14.4.1 CMOS LSIs are equipped in this unit, so care must be taken to avoid the electro-static charge, by ground human body, etc.

14.4.2 The normal static prevention measures should be observed for work clothes and benches.

14.4.3 The module should be kept into anti-static bags or other containers resistant to static for storage.

#### **14.5 Limited Warranty**

14.5.1 Unless otherwise agreed between C.I.E and customer, C.I.E will replace or repair any of its LCD and LCM which C.I.E found to be defective electrically and visually when inspected in accordance with C.I.E Quality Standards, for a period of one year from date of shipment.

14.5.2 The warranty liability of C.I.E is limited to repair and/or replacement. C.I.E will not be responsible for any consequential loss.

14.5.3 If possible, we suggest you use up all modules in six months. If the module storage time over twelve months, we suggest that recheck it before the module be used.

## **15 Packaging**

TBD

## **16 Prior Consult Matter**

1. For C.I.E standard products, we keep the right to change material, process for improving the product property without prior notice to our customer.

2. For OEM products, if any changes are needed which may affect the product property, we will consult with our customer in advance.

3. If you have special requirement about reliability condition, please let us know before you start the test on our samples.

**Reference**

<b>Item</b>	<b>Description</b>	<b>Revision</b>
FT101	IC Data sheet	V0
070D154	LCD	V0